

## CONTENTS

*Note.*—This book is made up of separate parts, or sections, as indicated by their titles, and the page numbers of each usually begin with 1. In this list of contents the titles of the parts are given in the order in which they appear in the book, and under each title is a full synopsis of the subjects treated.

	<i>Pages</i>
LOCOMOTIVE BOILERS, PART 1	
Construction and Details .....	1-36
Boiler Shell .....	1-25
General Description of Boiler Shell .....	1-3
Construction of Boiler Shell .....	4-13
Lap joints; Details of butt joint; Relative stresses on lap and butt joints; Back head; Door hole; Dome course and roof sheet; Smokebox and first course; Tube sheets, tubes, and flues; Minimum net gas area; Gas area through tubes and flues; Foundation ring; Water leg	
Smokebox Details .....	13-25
Names and purpose; Fixing height of table plate; Nesting; Smokestack; Exhaust pipe; Diameter of nozzle; Action of exhaust in producing draft; Blower	
Firebox .....	26-36
Description of Firebox .....	26-28
Parts of firebox; Firebox sheets; Grates	
Staying Firebox to Boiler Shell .....	28-32
Necessity for staying; Application of staybolts	
Renewal of Locomotive Fireboxes .....	33
Expansion of Firebox Sheets .....	34-36
Drafting of Steam Locomotives .....	37-57
Analysis of Smokebox and Firebox Design .....	38-44
Recommended Design of Smokebox Details .....	44-51
Assembly of Smokebox Details .....	52-53
Discussion of the Drafts .....	53-55
Locomotive and Fuel Performance Tests to Determine Advantages Due to Redrafting .....	55-57

## LOCOMOTIVE BOILERS, PART 2

	<i>Pages</i>
Construction, Details, and Maintenance—( <i>Continued</i> )	1-83
Firebox Appliances	1-14
Arch tubes; Firebrick arch; Combustion chamber; Thermic syphons; Oil-burning firebox; Water-tube firebox.	
Boiler Details	15-26
Tubes and flues; The steam dome; Grates; Ash-pan.	
Circulation in Boilers	27-28
Heating Surface	29
Boiler Evaporation	30-32
Locomotive Boiler Design	33
Construction of Boilers	34-36
Care of Boilers	37-43
Accident Investigation Report	44-48
Washing Oil Boilers	49-50
Testing of Boilers	51
Poor-Steaming Locomotives	51-54
Calculating Strength of Boiler Joints	55-83
Definitions Relating to Boiler Plate	55-56
Definitions Relating to Joints	57-61
Analysis of Strength of Lap Joints	62-64
Analysis of Butt Joints	65-68
Force Tending to Rupture Boiler Shell	69-73
Area to be considered; Calculating bursting pressure; Calculating working pressure.	
Calculation of Stresses on Firebox	74-76
Calculating Stresses Designated on Specific Card	77-82
Instruction for Inspection and Testing of Locomotive Boilers	83-96

## LOCOMOTIVE BOILERS

(PART 1)

Serial 1967A

Edition 3

### CONSTRUCTION AND DETAILS

#### BOILER SHELL

##### GENERAL DESCRIPTION

1. **Definition.**—The locomotive boiler is a steel shell for containing water, which, when converted into steam by the heat of the fire in the firebox, furnishes the energy to move the locomotive. Locomotive boilers are of the internal-firebox, straight-firetube type and are made up of a cylindrical portion, which contains the tubes and flues, a back end, which is enlarged and shaped to accommodate the firebox, and a smokebox at the front, on which the stack is placed.

2. **Description.**—An exterior view of a locomotive boiler is shown in Fig. 1, a sectional view taken lengthwise of the boiler is given in Fig. 2 (*a*), and a cross-sectional view is shown in (*b*). The boiler shell is made up of a number of sheets and courses, namely, the back head, an outside firebox sheet, one on each side, the roof sheet, the throat sheet, the dome course, the taper, or conical, course, the first course, and the smokebox. However, the names of the courses vary according to the location of the steam dome. Should the dome be placed on the course next to the smokebox, as is the usual practice with smokebox throats, the first course would become the dome course. Also, the taper course would become the dome course should the dome be located on it. In the absence of the steam dome on the course next to the roof sheet, this course would become the combustion-chamber course because the combustion chamber of the firebox projects partly into it. The rear end of the boiler is

shaped as shown in order to conform to the shape of the firebox on the inside, the firebox being rectangular. The rear end of the boiler is riveted to the foundation ring *a*, Fig. 2 (*a*), which serves as a base to secure this part of the boiler to the frame of the locomotive.

The firebox, which comprises the firebox proper and the combustion chamber, is made up of a crown sheet, two side sheets, a door sheet, and a back tube-sheet. The back tube-sheet and the front tube-sheet are connected by flues *a* and tubes *a*<sub>1</sub>, which serve to carry the smoke and gases from the firebox to the smokebox. The arch tubes *b* serve to promote the circulation of the water around the firebox as well as to support the brick arch *b*<sub>1</sub>.

The purpose of the steam dome *d* is to collect and hold dry steam, from where it is conveyed through the throttle pipe and the dry pipe to the superheater. In the older types of locomotives, the throttle valve was located in the throttle pipe in the dome, but with the throttle in the smokebox and incorporated with the superheater header, the dome houses the dry pipe only. The four openings shown along the bottom of the boiler are the belly washout holes, and the angles shown at the rear of these holes are the waist-sheet angles to which the waist sheets are riveted. The purpose of the waist sheets is to secure to the frame of the locomotive the particular part of the boiler to which they are attached.

3. The throat sheet, Fig. 3, must be of a special shape because it serves to connect the cylindrical part of the dome course to the outside firebox sheets. One part of the sheet is flanged to conform to the cylindrical part of the dome course that rests on it, the remainder of the sheet, except where it is flanged to join the outside firebox sheets at *e*<sub>2</sub>, being flat. At the lower edge *e*<sub>1</sub>, the throat sheet is riveted to the foundation ring.

The smokebox, Fig. 1, the bottom surface of which is bolted to the cylinders of the locomotive, is the part of the boiler from which the products of combustion, after passing from the firebox through the tubes and the flues, are discharged to the



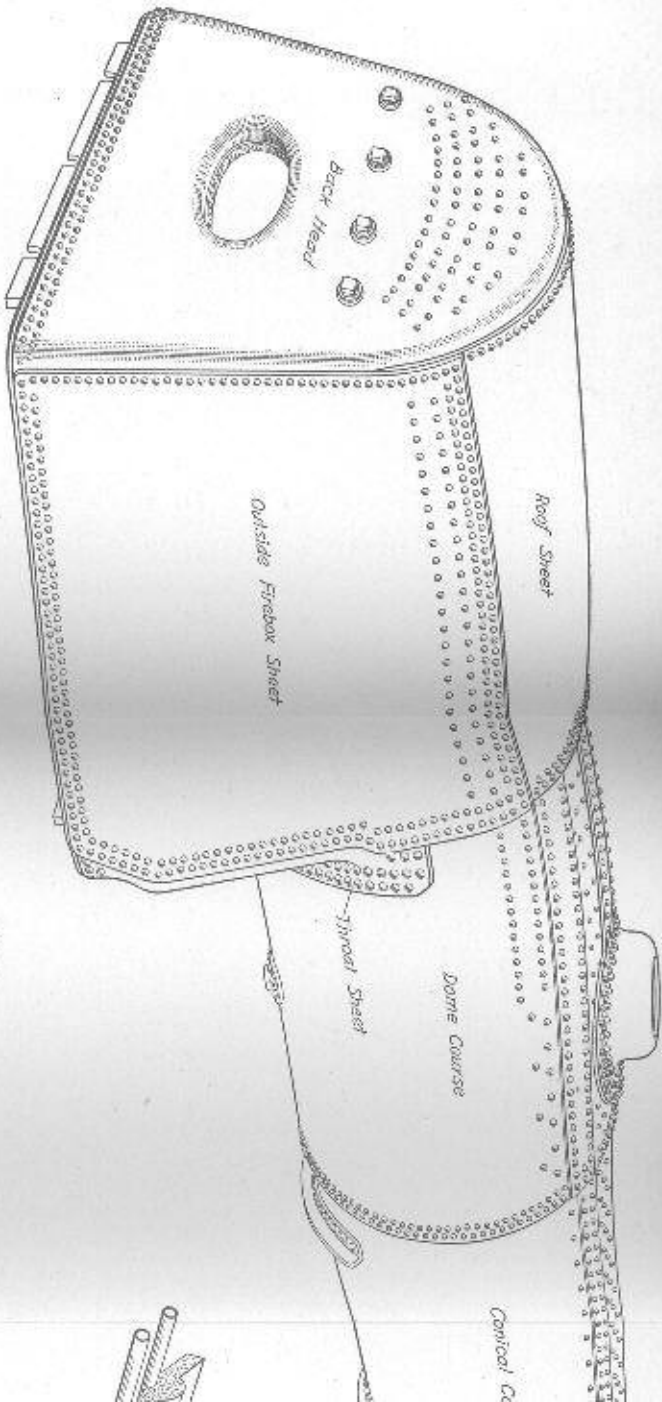
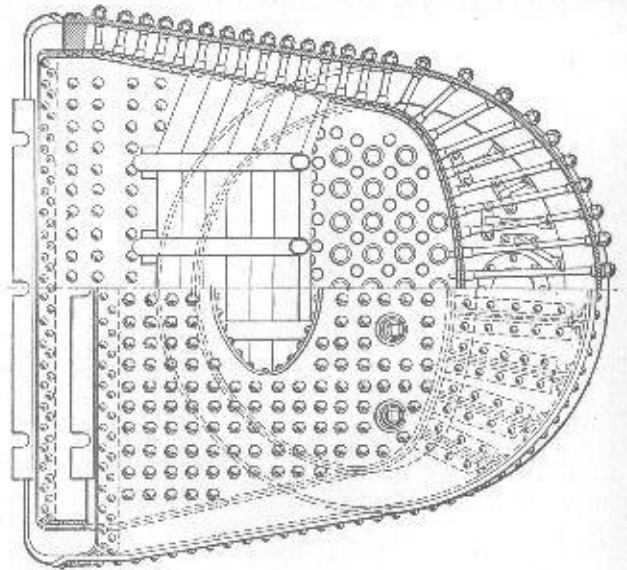

(b)

Fig. 1

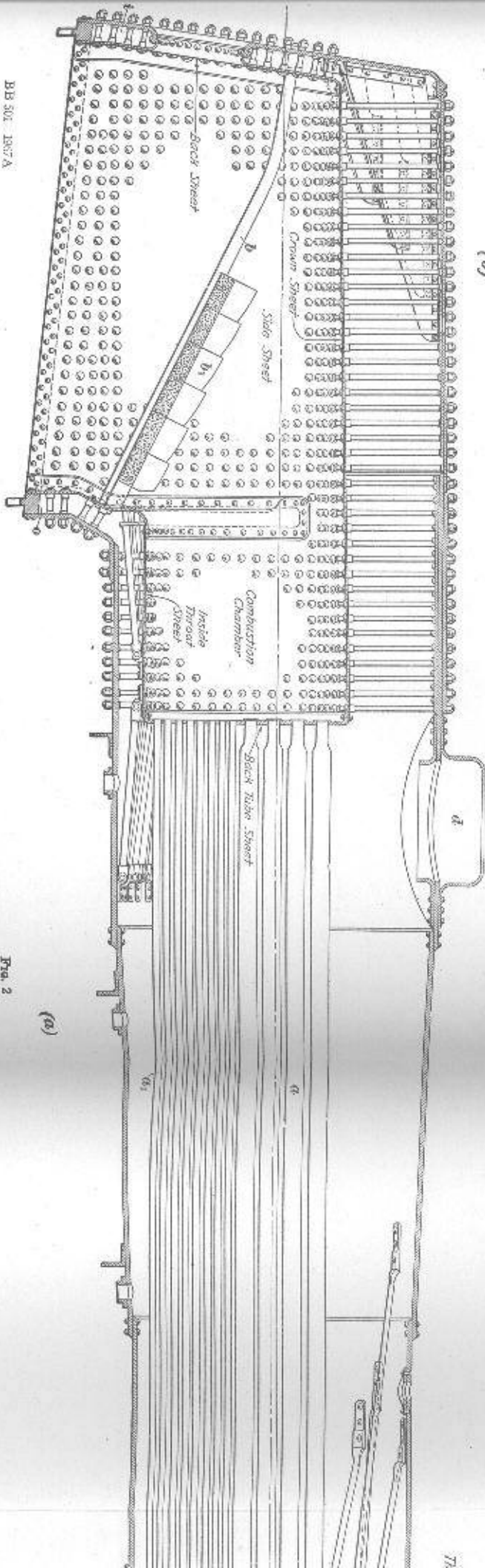

(a)

Fig. 2

BB 301, 1877 A

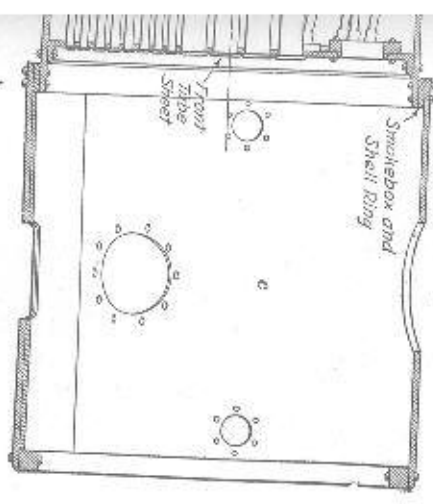
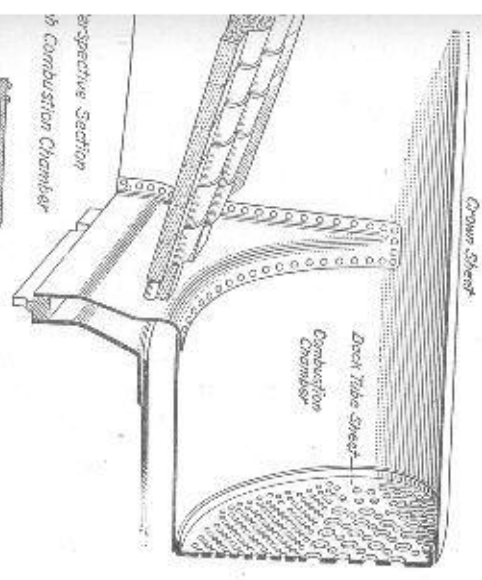
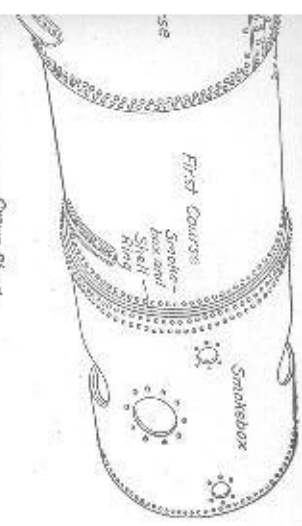

stack. Certain draft appliances are installed in the smokebox principally to prevent the emission of live sparks of such size as to cause fires, but also to make the smokebox self-cleaning. The smokebox is the only part of the boiler that is rigidly connected to the locomotive frame, the connections at the other points being flexible to permit the free expansion and contrac-

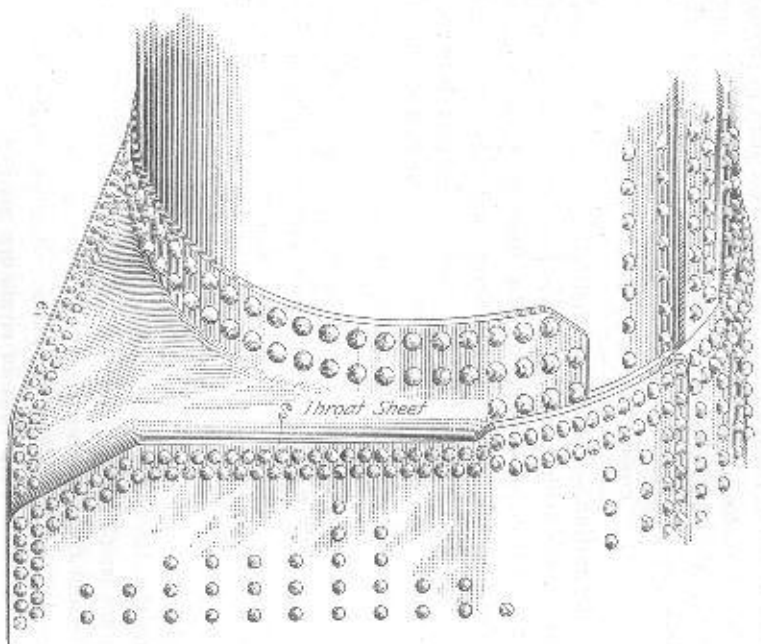

FIG. 3

tion of the boiler lengthwise due to heating and cooling. An exhaust pipe through which the exhaust steam from the cylinders is discharged to the smokebox projects upward into it through the opening shown. The heavy ring shown riveted inside the front edge of the smokebox, Fig. 2 (a), is the smokebox front ring and its purpose is to form a bearing for the attachment of

the smokebox front, which is a cast-iron or pressed-steel plate usually somewhat curved and which, with the smokebox door, closes the end of the smokebox. The smokebox door, which permits access to the interior of the smokebox, is hinged to the smokebox front and is held closed usually by nuts screwed onto studs set in the front. The smokebox bottom liner is riveted on the inside and at the bottom of the smokebox shell to strengthen it where the steam pipe opening is cut out and also to prevent wear on the smokebox shell by the abrasive action of the cinders.

#### CONSTRUCTION OF BOILER SHELL

**4. Definition.**—The boiler shell comprises all the exterior sheets of the boiler and therefore consists of the cylindrical courses in front of the firebox, the roof sheet, the back head, the throat sheet, the front tube-sheet, and the outside firebox sheets. However, boilermakers refer to the part between the firebox and the smokebox as the boiler shell and the other exterior sheets as the outer firebox sheets.

**5. Lap Joints.**—The boiler shell forward of the firebox is made up of circular courses, which vary in number according to the length of the boiler and are jointed together at the ends by lap joints. With this type of joint, the end of one course laps over the end of the course next to it and the two are riveted together. One, two, or three rows of rivets may be used, depending on the size of the boiler. When two rows of rivets are used, the joint is referred to as a double-riveted lap joint. The dome course and the first course, Fig. 1, are connected to the conical course by double-riveted lap joints. A triple-riveted lap joint is one in which three rows of rivets are used.

**6. Details of Lap Joint.**—In Fig. 4 (a) is shown an exterior view of a triple-riveted lap joint, and in view (b), a sectional view. One course *a*, view (b), fits on the inside of the course *b*, and the two are held together by three rows of rivets, *c*, which are driven to a full head on each side. When there are two or more rows of rivets, it is preferable to place the rivets in alternate rows, as shown in view (a). At *d*, view (b), is

shown a recess in the edge of the plate, which is made by calking it to insure a steam-tight joint. The calking should be done with a blunt round-nose tool held in a pneumatic hammer, care being taken that the plates are not sprung apart in the process of calking. Both the inside and the outside edges are sometimes calked to insure a more uniform job.

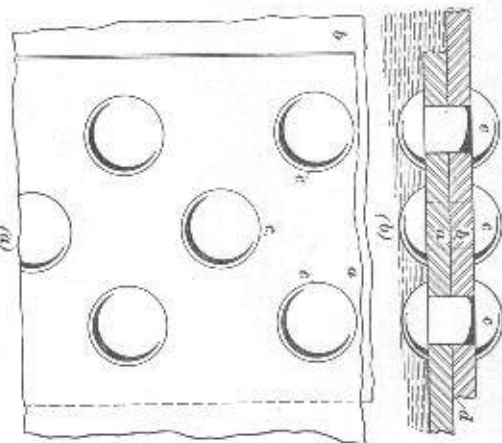

FIG. 4

**7. Butt Joints.**—The courses that comprise the cylindrical part of a boiler are usually made in one piece. When the ends of a course are connected, the seam will come lengthwise of the boiler, as shown in Fig. 1. The kind of joint which is used to connect the ends of the course is called a butt joint, because the ends butt together and do not overlap as in the girth joints.

**8. Details of Butt Joint.**—An exterior view of a butt joint is shown in Fig. 5 (a), and a sectional view in view (b). As shown in view (b), the ends *a* of the course are brought together but not overlapped, and strips, or welts, *b* and *c*, which cover the joint on the inside and the outside, are then riveted to the plate by rivets that pass all the way through.

The width of the inside welt is the distance between  $x$  and  $y$ , view (a), and the width of the outside welt is the distance between  $x_1$  and  $y_1$ . The dotted line  $x_2y_2$  shows where the ends of the course meet. The name applied to a butt joint depends both on the number of rows of rivets used on each side of the junction of the ends of the course and on the number of welts. In this case, three rows of rivets are placed on each side of the line  $x_2y_2$  and two welts are used, so the joint is referred to as a triple-riveted, double-welt butt joint. A quadruple-riveted, double-welt butt joint is one in which four rows of rivets and

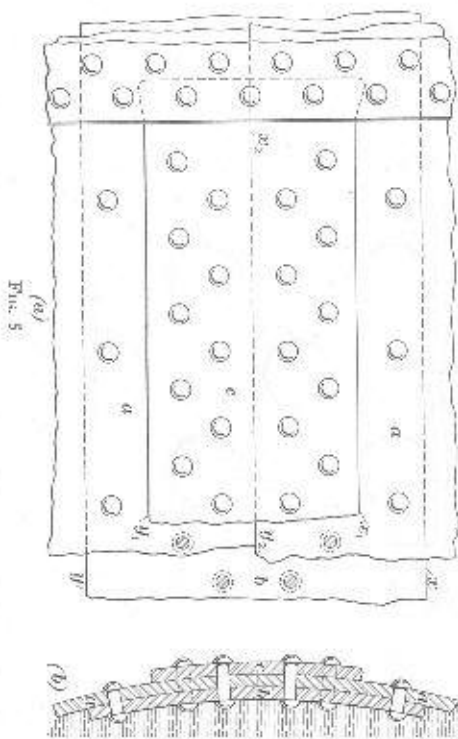

FIG. 5

two welts are used, and a quintuple-riveted, double-welt butt joint is one that employs five rows of rivets on each side of the seam and has two welts.

In the construction of a butt joint, the object should be to obtain a joint whose strength equals that of the solid plate as nearly as possible. The form of joint shown in Fig. 5 has a strength equal to about 90 per cent. of the solid plate; it is therefore said to have an efficiency of 90 per cent.

Welding is not permissible on the cylindrical part of the boiler because there are no additional means of strengthening the joint. On the other hand, the firebox is further supported by staybolts, so welded joints or seams are allowed.

**9. Relative Stresses on Lap and Butt Joints.**—Calculations show that a seam running lengthwise of a boiler course, such as a butt joint, is subject to nearly twice the stress that acts on a lap joint in the same course; therefore, a joint running lengthwise of the boiler will withstand only one-half the boiler pressure that a lap joint of the same construction will withstand. For this reason, care should be taken that butt joints be properly constructed to withstand the pressures and stresses to which they are subject. A lap joint, besides being subject to only half the stress of the boiler pressure, also is strengthened by the staying properties of the tubes and flues and by the stays that connect the front and back heads of the boiler.

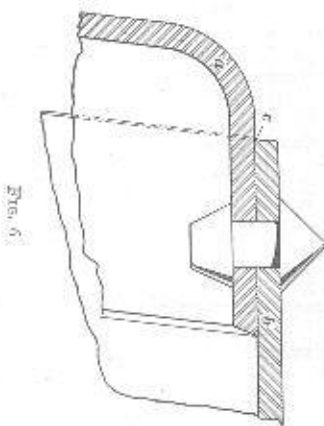

FIG. 6

**10. Back Head.**—The back head, Fig. 1, is connected to the roof sheet and the outside firebox sheets by a single riveted lap joint, and to the foundation ring by a double row of rivets. In Fig. 6 is shown a detail of the joint at the back head  $a$  and the roof sheet  $b$  with the sheet calked at  $c$ . A single row of rivets has been found sufficient to carry the strain on the back head because of the way the head is stayed at other points. The portion of the backhead below the crown sheet is rigidly stayed to the door sheet and the foundation ring. Above the crown sheet, the back head is stayed to the roof sheet by diagonal braces, one type being shown in Fig. 2 (a). Therefore, the greater part of the load on the back head is carried by the staybolts and the braces thereby relieving the stress on the rivets of the single riveted lap joint.

**11. Door Hole.**—The joint at the back head  $b$ , Fig. 7, and the door sheet  $f_2$  of the firebox to form the door hole is constructed in a number of different ways. As shown in view (a), the door sheet surrounding the door opening is flanged to a large radius and extends through to the back head, the two sheets being riveted together at  $o$ . In view (b), the door sheet is shown flanged outwards and the back head is flanged inwards, and the two are riveted together. View (c) shows what is called the sleeve door, in which both sheets are flanged outwards, and a separate piece is rolled to the shape of the

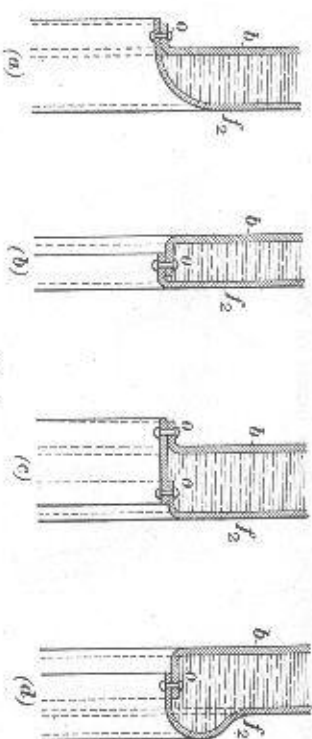

FIG. 7

door hole and is welded and then riveted to the sheets. Owing to the continual expansion and contraction caused by the alternate heating and cooling of the inner sheet around the fire-door as the door is opened and closed, the sheet, when flanged in a single curve as already shown, is liable to crack. A method of overcoming this is shown in view (d), where the door sheet is flanged to an ogree curve. This construction allows considerable movement of this sheet without causing any rupture or distortion. The door hole is the only point at which the firebox is riveted to the boiler shell.

**12. Dome Course and Roof Sheet.**—The dome course, or the combustion chamber course, as the case may be, is connected to the roof sheet in the same way as the cylindrical courses are connected; that is, if the cylindrical courses are connected by double-riveted lap joints, the same construction is used at the

junction of the dome course with the roof sheet. The joint extends down, as shown in Fig. 3, until it meets a similar type of joint in the throat sheet and the side sheets.

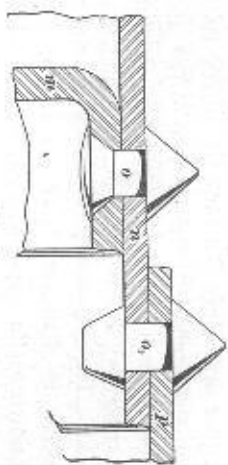

FIG. 8

**13. Throat Sheet and Side Sheets.**—As shown in Fig. 3, the throat sheet is connected to the side sheets and the cylindrical course by a double-riveted lap joint, but in some cases the connection is made by a triple-riveted lap joint.

**14. Smokebox and First Course.**—As shown in Fig. 8, the smokebox  $p$  is connected to an extension of the first course  $n$  beyond the tube-sheet  $m$  by a single or double row of rivets

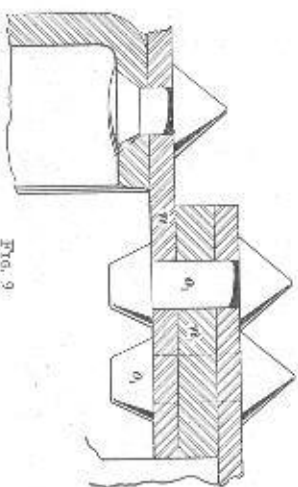

FIG. 9

$o_1$ . The smokebox may be riveted directly to the course  $n$ , as shown, or a wrought iron  $n_1$ , Fig. 9, called the smokebox ring, may be inserted between the course  $n$  and the smokebox. The ring provides a stopping point for the insulation that is applied to the outside of the boiler. Two rows of rivets  $o_1$  are generally used with the ring  $n_1$ .

**15. Tube Sheets, Tubes, and Flues.**—The end of the boiler course next to the smokebox is closed by the front tube-sheet, whereas the back tube-sheet forms the front end of the firebox. The tubes and the flues extend through the boiler from one tube sheet to the other and serve not only to convey the smoke and the gases from the firebox to the smokebox but also to act as stays for the tube sheets. At the firebox end, the tubes and the flues are electrically welded to the tube sheet all the way around to prevent leaks. The reason for the use of the flues, which are usually 3½ inches in diameter, is to accommodate a series of steam pipes known as the superheater units in which the steam,

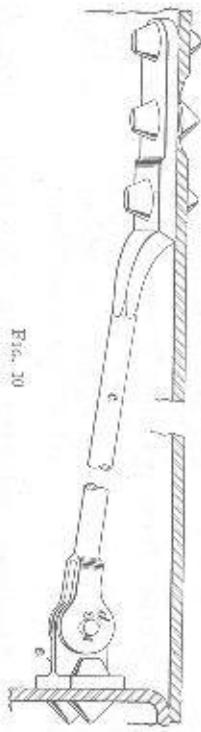

FIG. 10

in its passage to the cylinders, absorbs additional heat. Hence the flues have to be made larger than the tubes, which ordinarily are 2½ inches in diameter. In modern boilers, there are generally three or four times as many flues as tubes.

In Fig. 8 is shown how the front tube-sheet *m* is connected to the first course *n* by a single row of rivets *a*, which pass through the flange of the sheet and the outer course. The rivets *o* are sometimes driven slightly flattened, as shown, and sometimes with a flat head on both sides. The first method, which makes it easier to use the tube expanders on the side rows of tubes and also to calk the rivets should they leak, is the better one. In Fig. 10 is shown how the part of the front tube-sheet above the tubes and flues is braced. The front ends of the braces *c* are connected by the pins *d* with the T irons *e* riveted to the tube-sheet. The back end of the brace is flattened out sufficiently to allow two or three rivets to be used to connect it with the first course.

**16. Minimum Net Gas Area.**—The minimum net gas area of a flue is the cross-sectional area of the inside of the flue after

the area occupied by the superheater unit has been deducted. This area decreases with the higher steam pressures because the flue then has to be made thicker while it maintains the same outside diameter, or 3½ inches. A flue with an outside diameter of 3½ inches, used with a boiler carrying up to 200 pounds pressure per square inch, has, when the area of the superheater unit is deducted, a minimum net gas area of 6.1319 square inches.

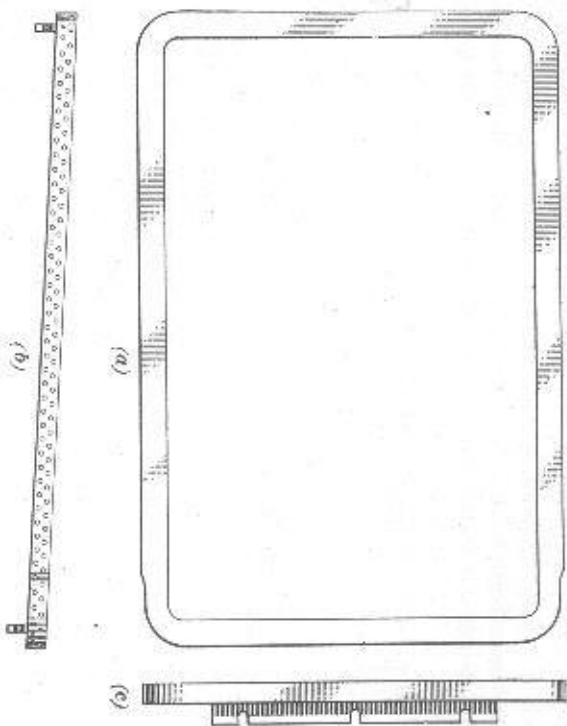

FIG. 11

For the same flue and with pressures up to 250 pounds, the minimum net gas area is 5.9898 square inches; and for pressures from 250 pounds to 310 pounds, the net gas area is 5.8476 square inches.

**17. Gas Area Through Tubes and Flues.**—The net internal gas area through the tubes and flues varies between 15 and 17 per cent of the grate area and is one of the most important factors in the design of the boiler. If the gas area is too small, the size of the nozzle must be reduced, thereby increasing the cylinder back pressure in order to draw the gases through the

tubes and flues. The maximum gas area that can be put into a boiler is influenced largely by the area of the front tube-sheet. The diameter of the front end of the boiler should be large enough for the front tube-sheet to take the maximum number of flues that can be installed in the back tube-sheet.

**18. Foundation Ring.**—The foundation ring, also called the firebox ring or the mud-ring, is a casting or forging that serves as a base to connect the rear end of the boiler with the frame of the locomotive and that also serves to space the firebox correctly with respect to the boiler shell. The rectangular part of the firebox fits within the foundation ring with the

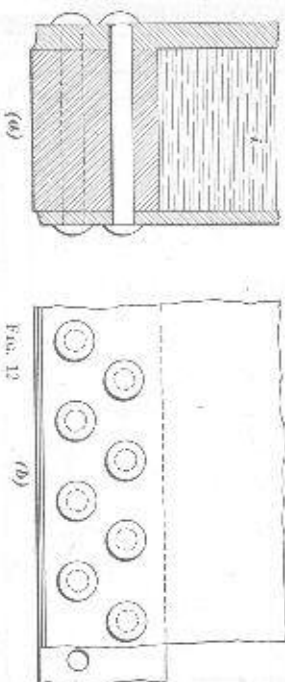

FIG. 12

edges of the sheets flush with the bottom surface of the ring. The outside firebox sheets, the back head, and the throat sheet are similarly placed around the outside of the ring, and the complete assembly is riveted together. The space formed by the separation of the sheets by the mud-ring is called the water-leg.

The foundation ring, as viewed from the top, is shown in Fig. 11 (a), and, as viewed from the side and the end, in views (b) and (c), respectively. A section taken through the ring and the firebox sheets is shown in Fig. 12 (a), and the sheets are riveted to the ring by two rows of zigzag rivets, headed over on each side, as shown in view (b). At their junction at the mud-ring, the edges of adjacent sheets are scarfed, chamfered, or beveled so that their total thickness will be the same as one sheet; hence the sheets will fit tight against the side of the ring. This is the only place where this type of joint is employed in a boiler.

Foundation rings are made from 5 to 7 inches wide and from 2½ to 4½ inches thick, depending on the width of the water-leg and whether one or two rows of rivets are used.

**19. Water Leg.**—The water-leg *i*, Fig. 12 (c), is the space between the side sheets and the door sheet of the firebox and the boiler shell, with a width at the bottom equal to that of the mud-ring. It is a very important part of the water space of the boiler because, containing water, it prevents the firebox sheets from becoming overheated by the extreme heat of the fire. The water evaporates very rapidly in the water-leg and this evaporation causes a continuous circulation of water around the firebox. The water is at its greatest depth in the water-leg, so the pressure at the bottom of the water-leg exceeds that at any other part of the boiler.

#### SMOKEBOX DETAILS

**20. Names and Purpose.**—In Fig. 13 is shown an arrangement of the smokebox details, known as the Master Mechanics' front-end design, with the smokebox partly broken away to make the arrangement clear. The design consists of an exhaust pipe, or stand, *a* with a round-bore exhaust nozzle *b*, a smoke-stack *c* with a stack extension *d* bolted to it, a diaphragm *e*, a table plate *f* supported by the exhaust pipe and attached to the diaphragm and the sides of the smokebox, an adjustable diaphragm apron, or damper, *g* attached to the front of the table plate, and a sloping smokebox netting *h* attached to the table plate and the interior of the smokebox. The purpose of the diaphragm, the table plate, the damper, and the netting is to offer an obstruction to the flow of the sparks and the cinders in their passage to the stack, thereby breaking them up into such small pieces that they will cool quickly after leaving the stack and hence reduce the fire hazard.

**21.** The diaphragm conforms in shape to a part of the circumference of the smokebox and hence is semicircular. It is applied either vertically or with a slight slope about 30 inches ahead of the front flue-sheet and introduces a partition in the smokebox down to the junction of this plate with the table plate.

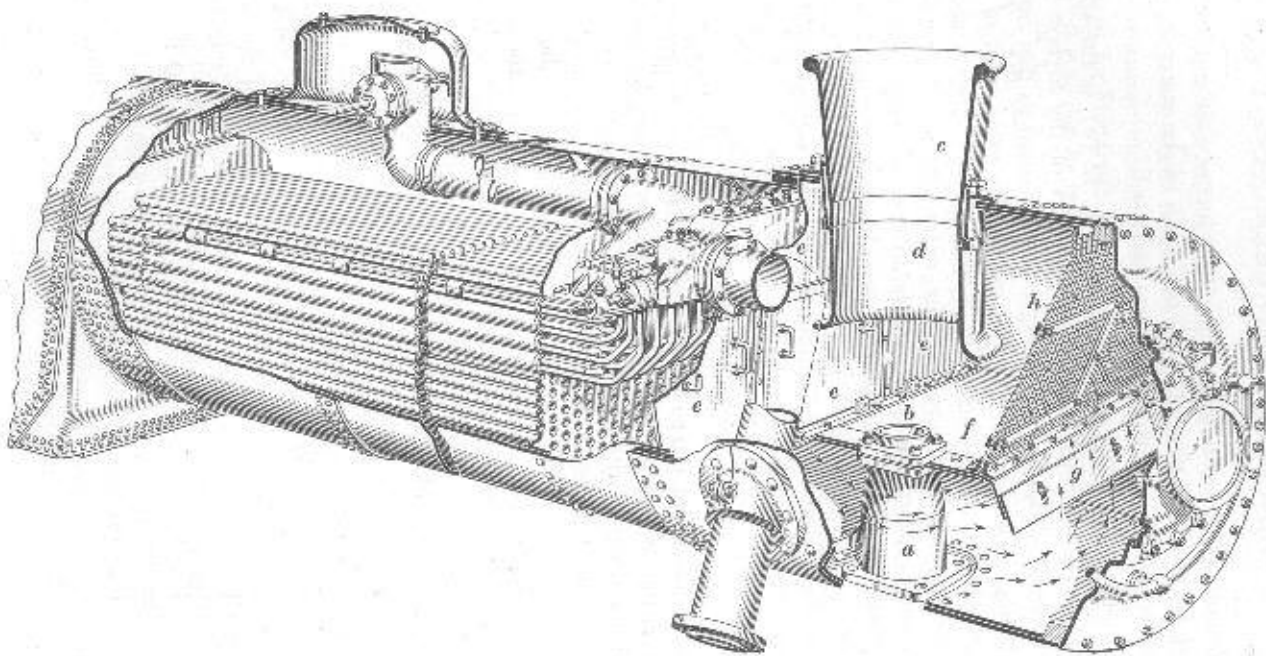

FIG. 13

The edge of the diaphragm is bolted to angle irons on the interior wall of the smokebox, the fit of the plate being such as to be spark-tight. The two flanges of the superheater header to which the steam pipes are connected pass through the diaphragm, and here, also, the plate fits the flanges close enough to prevent the escape of sparks. The diaphragm is made in several sections to facilitate removal and application when making repairs to the tubes, the flues, and the superheater units.

The pulsating draft, produced by the partial vacuum developed in the smokebox at each discharge of the exhaust steam, carries the sparks and the cinders against the diaphragm and causes them to break up into smaller pieces.

The table plate is rectangular in shape and is applied horizontally. It is connected both to the diaphragm and to the wall of the smokebox by angle irons. The exhaust pipe projects through an opening in the table plate, the edges of the plate being caught between the exhaust pipe and the exhaust nozzle when these parts are bolted together. The partial vacuum in the smokebox that follows each exhaust acts to lift the sparks and cinders up against the table plate and causes them to be broken up.

The diaphragm apron, or damper, also assists in breaking up the solid products of combustion, but its real function is to regulate the intensity of the draft through the fire and prevent it from being torn by the heavy exhausts at low speeds.

If there were no damper at all, the gases would rush into the smokebox as rapidly as the resistance of the tubes and the arch would permit them to flow, and, as the resistance of the grates and the fuel bed would allow the air to enter the firebox, the result would be a draft of sufficient intensity to tear the fire at low speeds. However, when an adjustable damper is used, the space through which the products of combustion have to pass to enter the front of the smokebox can be changed as desired. If the draft through the fire is insufficient, a higher adjustment of the damper will increase the space beneath it and so increase the effectiveness of the partial vacuum in the smokebox in producing a draft through the fire. If the draft is too strong, a lower adjustment will lessen the space and thus will

decrease, or dampen, the effectiveness of the smokebox vacuum in causing air to be drawn through the fire and will reduce the draft. Hence, raising the damper will increase the total draft through the fire, and lowering it will decrease the draft.

22. It was formerly thought that the draft could be equally distributed through the fire by adjusting the damper, but carefully conducted experiments have shown that raising or lowering the damper has no effect on an equal distribution of the draft. With an arch fitted close against the fire sheet, the draft is always stronger through the rear grates because the arch, being open at the rear, offers no obstruction to the flow of the air.

Some railroads secure an equal distribution of air through the fire by using grates of a smaller opening at the position of greater draft, or at the rear, and grates of a greater opening at the point of less draft, or at the front.

23. **Finding Height of Table Plate.**—The various heights at which the table plate must be placed to obtain certain gas areas beneath it for different smokebox diameters are given in Table I. The table can be used also to obtain the height of the diaphragm apron, or damper.

The preferred maximum and minimum areas under the table plate are 95 per cent and 85 per cent, respectively, of the minimum net gas area through the tubes and the flues, and the preferred area under the diaphragm apron is 75 per cent.

The following example illustrates the use of the table:

**EXAMPLE.**—It was found that 95 per cent of the minimum net gas area through the tubes and the flues was 1,543 square inches and that 75 per cent of the gas area was 1,218 square inches. What should be the height of the table plate and the diaphragm apron if the inside diameter of the smokebox is 84 inches?

**SOLUTION.**—By following the column under 84 in Table I down to the number 1,543, it will be found that the number opposite 1,543 in the column headed Height of Table Plate is 27 in. Ans.

To find the height of the diaphragm apron for an area not given in the table, such as 1,218, select under the proper smokebox diameter the nearest gas area and height of diaphragm apron, which in this instance are 1,235 and 23 respectively, then multiply 1,218 by 23 and divide by 1,235.

$$\frac{1218 \times 23}{1235} = 22\frac{1}{2} \text{ in. Ans.}$$

TABLE I  
HEIGHT OF TABLE PLATE

Height of Table Plate, Inches	Smokebox Diameters, Inches										
	66	68	70	72	74	76	78	80	82	84	86
	Areas Under Table Plate, Square Inches										
15	586	595	605	613	625	636	646	655	663	674	682
16	642	653	663	672	685	697	708	719	728	739	748
17	699	711	722	733	747	760	772	784	793	806	816
18	758	771	783	795	810	824	837	850	861	874	886
19	817	831	845	858	874	890	904	918	929	944	957
20	877	893	908	922	939	957	972	986	999	1,015	1,028
21	939	955	972	987	1,006	1,024	1,040	1,056	1,070	1,087	1,103
22	1,001	1,019	1,037	1,053	1,073	1,093	1,110	1,127	1,142	1,160	1,177
23	1,063	1,083	1,102	1,120	1,141	1,163	1,181	1,199	1,216	1,235	1,253
24	1,126	1,148	1,169	1,187	1,210	1,233	1,252	1,272	1,290	1,310	1,330
25	1,190	1,213	1,235	1,256	1,279	1,304	1,325	1,346	1,365	1,387	1,408
26	1,235	1,279	1,303	1,325	1,350	1,376	1,398	1,421	1,441	1,465	1,487
27	1,319	1,345	1,371	1,394	1,420	1,449	1,472	1,497	1,518	1,543	1,566
28	1,384	1,412	1,439	1,464	1,492	1,522	1,547	1,573	1,585	1,622	1,646
29	1,450	1,479	1,508	1,535	1,564	1,595	1,622	1,649	1,674	1,702	1,728
30	1,561	1,547	1,578	1,606	1,636	1,669	1,698	1,727	1,753	1,782	1,809

24. **Netting.**—The netting, Fig. 13, extends upward from the point where the table plate and the apron meet to the top and front of the smokebox. Its purpose is to prevent sparks that have not been sufficiently reduced in size by the other

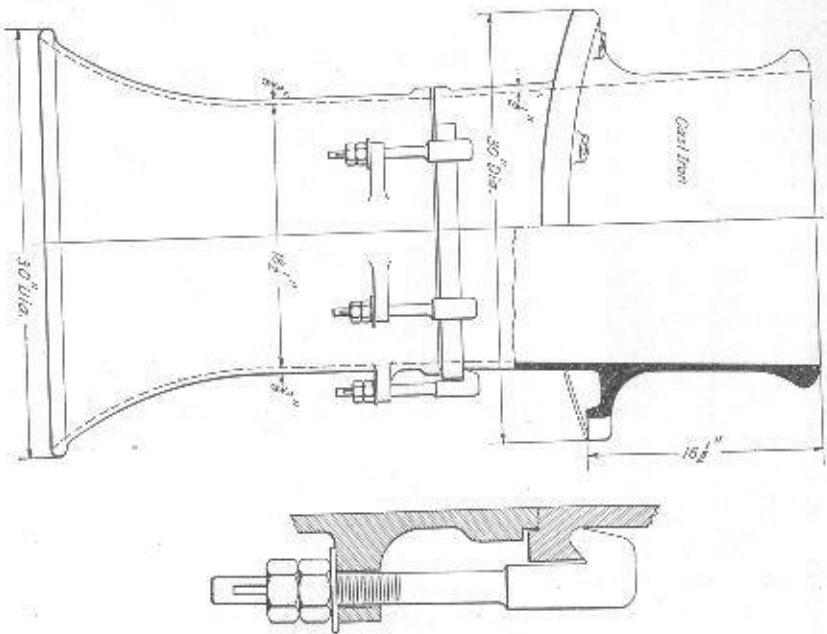

Fig. 13

smokebox appliances, iron being pulled through from the firebox and thrown out of the stack by the action of the exhaust. The netting consists of a network of wires about  $\frac{3}{8}$  inch in diameter and with a mesh about  $\frac{1}{8}$  to  $\frac{1}{4}$  inch square, or it may consist of a perforated steel plate. The netting is held in position by being bolted to the table plate and to angle irons on the sides

and the top of the smokebox, or it may be bolted to a piece of plate which extends down a short distance from the top of the smokebox. The preferred total area of the openings in the netting is 130 per cent of the total minimum net tube-and-flue-area of the boiler. The netting obstructs the flow of gases to such an extent that the size of the nozzle must be decreased slightly to produce the same amount of draft that would be obtained if no netting were used. Experiments have shown that the obstruction to the gas flow caused by the netting is equal to the combined effect of the diaphragm, the table plate, and the damper. For this reason, a smokebox arrangement has been designed on the centrifugal principle and no netting is used.

25. **Smokestack.**—The smokestack, or stack, is a cast-iron pipe that is bolted to the top of the smokebox. Its purpose is to carry off the products of combustion from the smokebox to a point above the engine and the train. Fig. 14 is a half-outside and a half-sectional view of a tapered stack of cast iron, which is used on boilers of large diameter. This stack is largest at the top, from where it tapers to the top of the stack extension, which is connected to the base of the outside stack, as shown, and projects down into the smokebox close to the nozzle. The purpose of the stack extension is to make the stack of such height that, when the engine is running at moderate speed, one exhaust is entering at the bottom of the stack before the preceding one has escaped at the top, thus preventing a rush of cold air down the stack to fill the vacuum in the smokebox.

With large boilers, the stack, owing to clearance limitations, must be made short and, since it is not of sufficient height to prevent the entry of air, it is accordingly lengthened by the stack extension. The smokestack must be set in an exactly vertical position on the boiler, and its center must line up accurately with the center of the exhaust nozzle.

26. **Exhaust Pipe.**—The exhaust pipe is made of cast iron and is used to conduct the exhaust steam from the cylinders

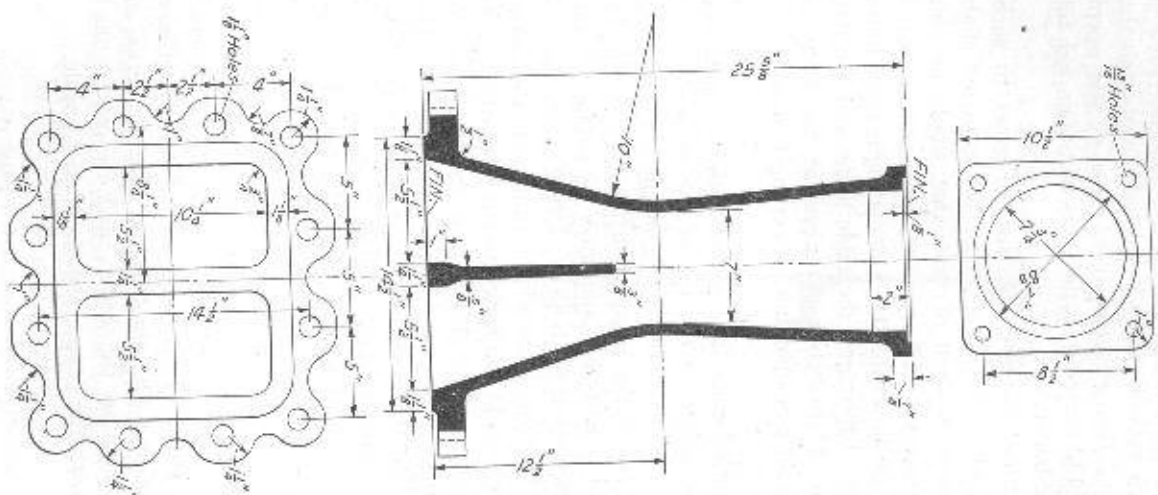

FIG. 15

and auxiliaries to the proper point in the smokebox. The intensity of the draft is governed by the exhaust nozzle on the top of the exhaust pipe.

A print of an exhaust pipe is shown in Fig. 15. The top is machined and drilled for the exhaust nozzle, Fig. 16, and the base is machined and drilled where it rests on the cylinders.

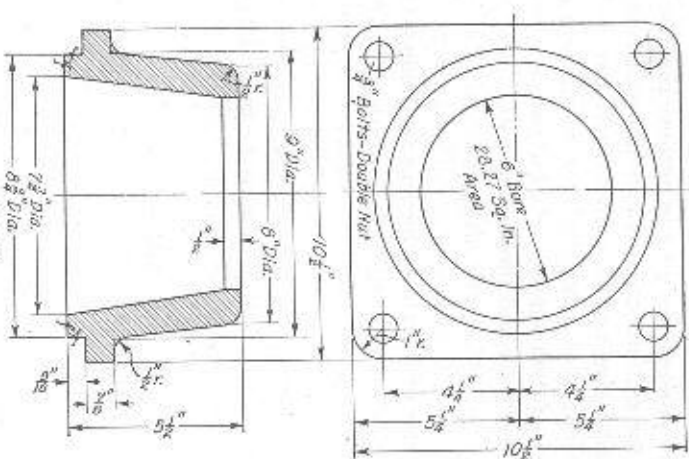

FIG. 16

The base must make a steam-tight joint and both surfaces are spotted in with a surface plate. To do this, the surface plate is coated with red lead and then rubbed on the base of the pipe and its seat on the cylinders; the high spots are filed and scraped after each application of the plate until the surfaces are flat. The surfaces are then ground into each other by using a grinding compound and rubbing one over the other. The exhaust nozzle is ground into its seat in practically the same way.

The exhaust pipe is secured to its base by twelve studs, and the nozzle is recessed into the end of the exhaust pipe and is held in place by four studs.

In the application of an exhaust pipe, the opening in its base must coincide exactly with the opening in the cylinders. The pipe then serves as an extension of the exhaust passages. The opening through the nozzle should be of such size as to cause the steam that passes through it to produce the desired draft on the fire. If the exhaust nozzle is unduly contracted, the force of the exhaust steam will be extremely violent and holes will be torn in the fire. A contracted nozzle will also increase the back pressure in the cylinders. If the nozzle is too large, the draft will be too weak and the required amount of fuel will not be burned.

**27. Diameter of Nozzle.**—One rule for finding the diameter of a single circular exhaust nozzle is to use 22½ per cent of the diameter of the cylinder for the diameter of the nozzle. In Table II is shown the correct nozzle sizes calculated on this basis for cylinders from 20 to 32 inches in diameter. If a bridge is used in the nozzle, it must be made larger so as to retain the net area given in the table.

TABLE II  
EXHAUST-NOZZLE SIZES—SIMPLE, TWO-CYLINDER

Boiler Details	Diameter Sizes												
	Inches												
Cylinder	20	21	22	23	24	25	26	27	28	29	30	31	32
Exhaust Nozzle	4½	4¾	5	5¼	5½	5¾	5¾	6¼	6½	6¾	6¾	7	7¼

**28. Draft.**—Draft in a locomotive is the term applied to the rapid flow of air through the grates and the fire that occurs when the locomotive is working. Draft is divided into two classes, natural and forced. With natural draft, no apparatus or force is used to induce the flow of gases other than the difference between the weight of the hot gases in the firebox and the stack and that of the cooler air outside. The draft

through a locomotive boiler, when the engine is standing and the blower not working, is natural draft. Forced draft, as the name implies, means that the draft is induced by other means. The flow of air through the grates, firebox, and tubes into the smokebox and out of the stack when the locomotive is working is an example of forced draft.

**29. Action of Exhaust in Producing Draft.**—The action of the exhaust steam in producing a draft is as follows: The exhaust steam passes from the cylinders through the exhaust pipe and the stack to the atmosphere and, in doing so, carries out by induced action some of the smokebox gases and causes a partial vacuum in the smokebox. The movement of the air at atmospheric pressure through the grates and the fire to fill the area of lower pressure in the smokebox causes a draft on the fire. The greater the force of the exhaust, the greater will be the degree of vacuum in the smokebox and the stronger will be the draft through the fire. As the partial vacuum in the smokebox follows each discharge of the exhaust steam, the draft is pulsating rather than steady, this action being more noticeable at low than at high speed. The term, partial vacuum, as here used, means that the pressure of the gases in the smokebox after an exhaust is less than the pressure of the atmosphere, which is about 15 pounds to the square inch. The jet of exhaust steam should not fill the stack, whether it is large or small, until at a point very near the top, as shown in Fig. 17.

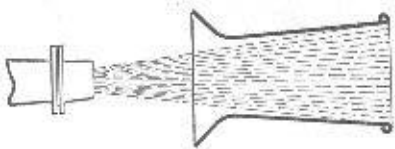

FIG. 17

**30. Blower.**—The action of the exhaust steam in passing through the exhaust nozzle produces a draft through the fire only when the engine is working steam. The blower provides a means whereby a draft is produced when the engine is standing or is running with steam shut off. The blower consists of a pipe that conveys steam from a valve in the cab to the exhaust nozzle, or at a point near the base of the stack which ever may be found the more convenient.

In Figs. 18 and 19, two different arrangements of the blower pipe at the smokebox are shown. As shown in Fig. 18, the pipe from the boiler head connects outside the smokebox to a pipe that enters the exhaust pipe or the exhaust nozzle. A

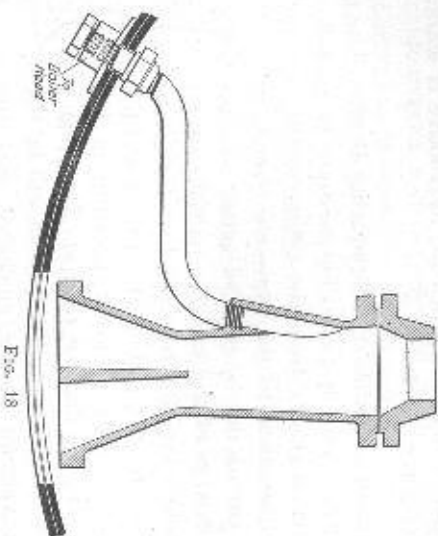

FIG. 18

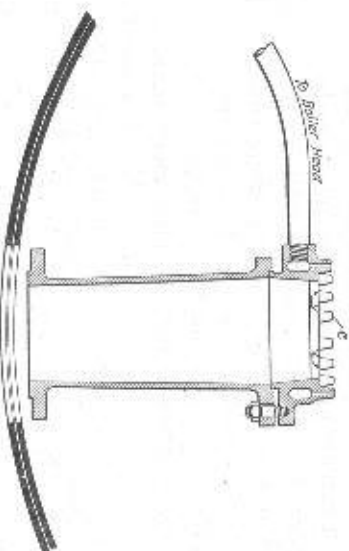

FIG. 19

plug is provided at the junction of the pipes so that a steam hose can be connected and a draft created when the boiler is fired up in the roundhouse. The blower pipe may be connected to the side of the exhaust pipe, as shown in Fig. 18, or it may be screwed into the exhaust nozzle, as shown in Fig. 19, the outlet for the steam being through the small holes in the

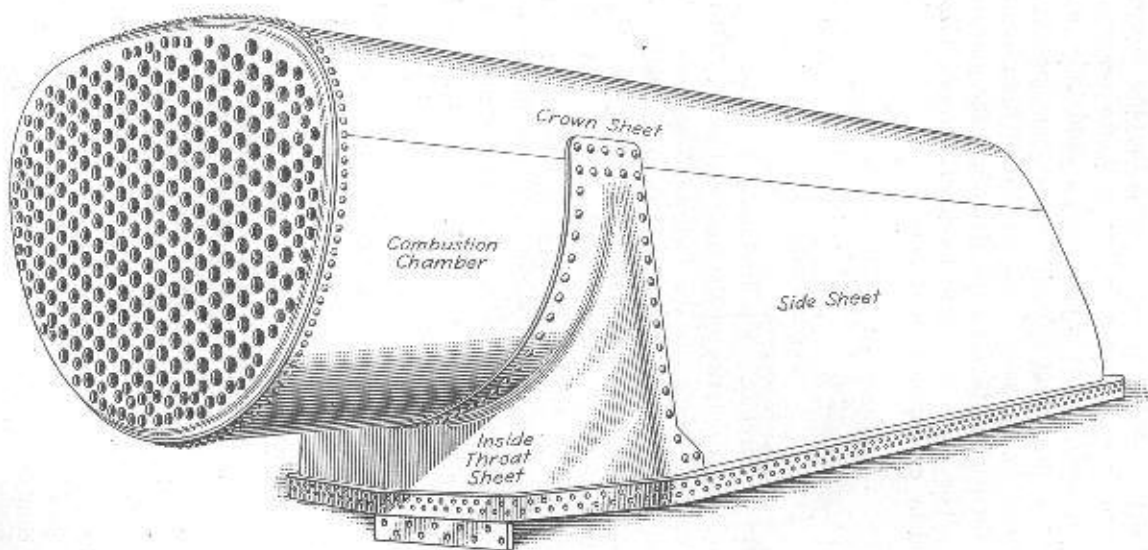

FIG. 20

vertical projections *c*. The simplest arrangement for a blower is to bend a pipe in the smokebox until the end is near the top of the nozzle and directly in line with the center of the stack. When the blower is in operation, a steady flow of steam passes through the blower pipe and the exhaust nozzle. The draft is created by the same action as that of the exhaust jet, that is, by the friction between the steam and the gases in the smokebox. The gases are carried out of the smokebox and are replaced by air through the grates.

### FIREBOX

#### DESCRIPTION

**31. Parts of Firebox.**—The firebox is a compartment, or box, inserted in the interior of the back end of the boiler shell and so spaced with respect to the shell as to be surrounded by water on all sides. It is in the firebox that the fuel is burned and its heat transmitted to the water. An exterior view of a firebox ready to be applied to a boiler is shown in Fig. 20, and the shell of the boiler, cut away to show a front view of the firebox in the interior, is shown in Fig. 21. The firebox may be considered as being made up of two parts, the rectangular-shaped part, in which the solid part of the fuel is burned on the grates, and the barrel-shaped part, known as the combustion chamber, which serves to promote the combustion of the gases that escape from the coal and thus to secure additional heat from them before they enter the flues.

**32. Firebox Sheets.**—The firebox comprises certain sheets, generally  $\frac{3}{4}$  inch thick, which are joined together by either welding and riveting or by welding alone. The sheets that make up the firebox are the crown sheet, which forms the top or roof of the firebox and the combustion chamber, the door sheet, the two side sheets, the back-flue sheet, the combustion-chamber sheet, or the part of the combustion chamber not included in the crown sheet, and the inside throat sheet, which joins the cylindrical combustion chamber to the rectangular part of the firebox.

The crown sheet is welded to the two side sheets and the combustion-chamber sheet, and the inside throat sheet is riveted to the side sheets and the combustion-chamber sheet by a single row of rivets. The back-flue sheet, which closes the end of the combustion chamber, is headed as shown, and is secured to it by a single row of rivets, which give the joint ample strength, the flue sheet being further stayed by the flues. The door sheet which forms the back of the firebox, is flanged and

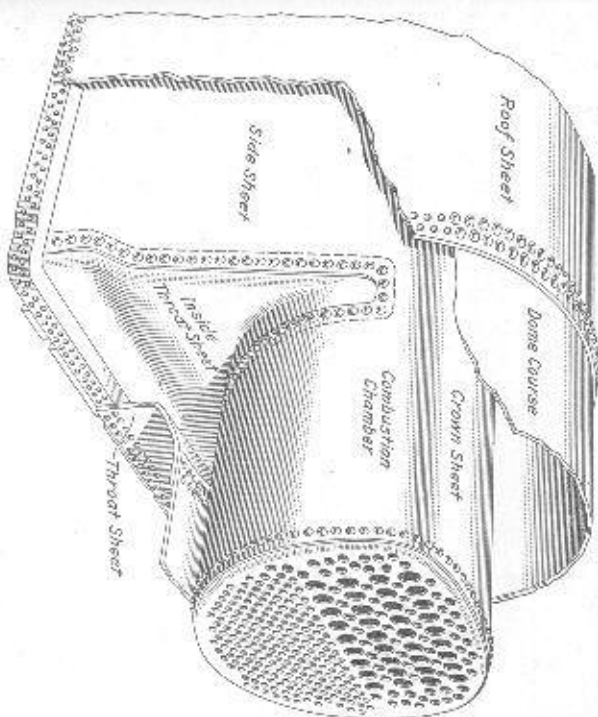

FIG. 21

is placed within the adjacent sheets, the joint being made by a single row of rivets. The strength of this joint is supplemented by the staybolts used to stay the door sheet to the back head of the boiler.

The heads of the rivets, particularly at the door sheet, are countersunk on the fire side, as shown in Fig. 22, so as to expose less metal to the action of the fire and reduce overheating of the rivet heads with consequent leakage.

**33. Grates.**—The bottom of the firebox is closed by the grates, on which the fuel is retained until it is burned. The grate area, which is found by multiplying the length of the firebox proper by its width, varies between 80 and 100 square feet, depending on the size of the boiler.

The relationship between the grate area in square feet and the firebox volume in cubic feet must be such as to give the carbon and the gases of the fuel time to mix intimately with the oxygen and to burn before entering the flues. A firebox volume of between 5.25 and 6.50 cubic feet for each square foot of grate area gives good results. About the same relationship should exist between the grate area and the firebox heating surface, that is, the surface of the firebox exposed to the heat of the fire on one side and to the water on the other.

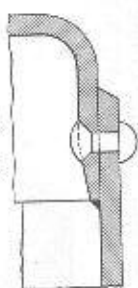

FIG. 22

#### STAYING FIREBOX TO BOILER SHELL

**34. Necessity for Staying.**—The firebox is subjected not only to the pressure of the steam but also to the weight of the water, so the tendency would be to force the crown sheet downwards, and the side sheets, the back-tube sheet, and the door sheet inwards. The firebox sheets are comparatively thin, about  $\frac{3}{8}$  inch, and would collapse under the load to which they are subjected unless supported by the thicker and more rigid sheets of the boiler shell. These sheets vary in thickness, depending on the boiler pressure, and may be  $\frac{3}{8}$ ,  $1\frac{1}{8}$ ,  $\frac{1}{2}$ ,  $\frac{3}{4}$ , or even 1 inch in thickness.

The thickness of the firebox sheets must be kept within certain fixed limits, because, if they are too thick, the transfer of the heat through them to the water would be too slow and they would become overheated. However, the boiler shell may be made of thicker sheets than those of the firebox. The firebox is prevented from collapsing by having all of its surfaces, with the exception of the tube sheet, stayed to the surrounding sheets of the boiler by staybolts spaced about  $4\frac{1}{2}$  inches apart. The staybolts vary in length, depending on the distance between

the firebox and the boiler, this distance being greatest at the crown sheet of the firebox and least at the mud-ring.

The long staybolts, such as are used at the crown sheet, are called crown stays. The shorter ones are referred to as staybolts, and the ones used where the side sheets curve to meet the crown sheet are called radial stays.

**35. Staybolts.**—The staybolts used to stay the firebox to the adjacent sheets of the boiler are of either the rigid or the flexible type. A rigid staybolt is one in which each end is

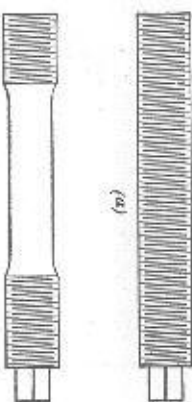

FIG. 23

threaded and screwed into the boiler shell and the firebox and the projecting ends riveted over. The ends of this type of staybolt are then rigid with respect to the sheets and are subject to stresses when the sheets expand and contract with temperature changes. A flexible staybolt is one that is designed to permit of the unequal expansion and contraction of the firebox and the boiler shell without imposing undue strains on either the sheets or the bolt. Flexibility of movement is obtained by making the outer end of the bolt ball-shaped where it contacts the boiler shell.

A rigid staybolt with a straight body is shown in Fig. 23 (a), and one with a reduced body to make the application easier is shown in view (b). The tall-tale holes that are always drilled in these bolts are not shown. Square ends are forged on the staybolts to permit them to be threaded during manufacture as well as to be screwed into the sheets. The square end as well as any other surplus stock is cut off after application, only enough stock remaining to permit riveting over. These

types of staybolts comprise the greater number used to stay the side sheets and the door sheet of the firebox to the adjacent sheets of the boiler.

36. The rigid crown staybolts used to stay the crown sheet to the roof sheet differ from the shorter rigid staybolts in that

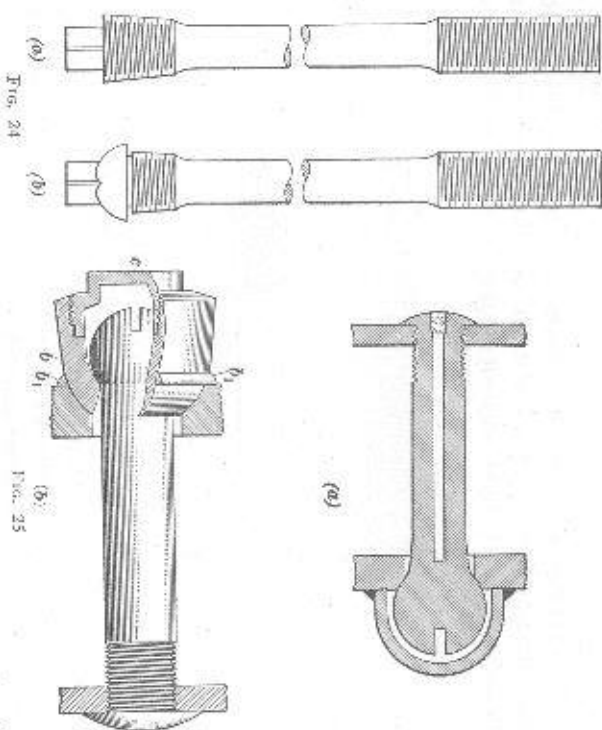

the firebox ends of the bolts have either a threaded taper head, as in Fig. 24 (a), or a button head, as in view (b). As the crown sheet will be the first to overheat with low water, it will not pull away from a bolt with the end threaded on a taper or with a button head, as readily as from a straight-threaded bolt. The part of the head of a button-head crown staybolt that seats against the crown sheet is slightly undercut or dished out. Then, when the head is tightened against the sheet, the outer edge of the head contacts the sheet first and makes a tight joint. Most of the staybolts used to stay the crown sheet are of the rigid type.

In Fig. 25 (a) is shown one example of a flexible staybolt applied to the side sheet and comprising a two-piece assembly,

and in view (b) is shown a three-piece assembly. With the two-piece assembly, the seat in the boiler shell is shaped to fit the ball-shaped end of the bolt, whereas in the three-piece assembly the head of the bolt seats in the sleeve *b*, which has a removable cap nut *c*. In both cases, the cap and the sleeve are welded to the boiler shell, as shown at *b<sub>1</sub>*. The head of the bolt will turn slightly on its ball-shaped seat as the firebox expands and contracts; thus, the stress on the staybolt and the sheet will be less than if the outer end were rigid.

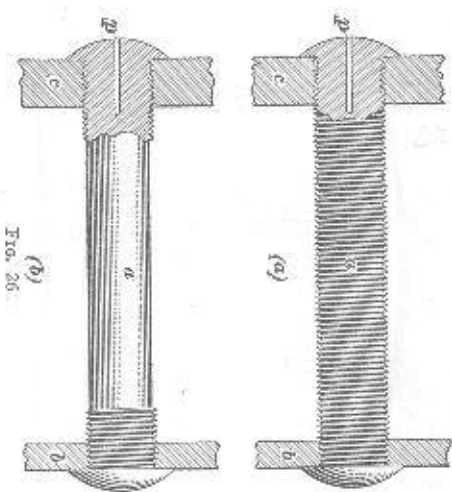

37. The practice on some railroads is to use flexible staybolts entirely to stay the firebox to the surrounding sheets of the boiler. On other roads, flexible staybolts are installed only in what is known as the breaking zone, which is that part of the area of the firebox where the movement of the sheets, and hence the tendency to breakage, is the greatest, and staybolts of the rigid type are applied elsewhere. The flexibility of a rigid staybolt increases with its length; hence where the longest staybolts are used, as at the top of the crown sheet, the rigid ones are assumed to be sufficiently flexible for the purpose.

38. Application of Staybolts.—When rigid staybolts are applied, the holes in the sheets, which have been previously drilled or punched, are reamed and tapped in the same opera-

tion with a combined tapered reamer and tap, thereby bringing the threads of one sheet in alignment with the threads of the other. The staybolts are then screwed into place and the ends cut off far enough from the sheet to leave sufficient metal for heading over and riveting. The ends are riveted over by backing up one end at a time and riveting over the other end. In Fig. 26 (a) and (b) is shown the application of rigid staybolts *a* to the side sheets *b* of the firebox and the boiler shell *c*. The application of a button-head staybolt is shown in Fig. 27 (a), and a taper-head staybolt in view (b). The ends

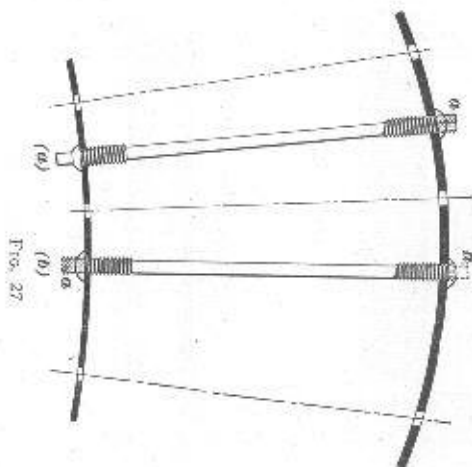

FIG. 27

of the bolts, before being riveted over, are indicated by *a*. The square ends of the button-head type of staybolts are cut off before the boiler is placed in service. As staybolts break frequently, tell-tale holes, as shown at *p*, Fig. 26, are drilled in the outer ends of the bolts so that they may be detected, when they break, by the discharge of water. The bolts invariably break next to the sheet at their outer ends, because it is here that the leverage induced by the movement of the firebox sheets is the greatest.

When applying the flexible staybolt shown in Fig. 25 (a), the holes in the outer sheet and the firebox are reamed and brought into line, and the seat is machined for the ball end of

the bolt. The bolt is then screwed into place and the end is riveted over, the ball end being backed up by a tool shaped to fit the head so as to prevent it from being distorted and enable it to make a true seat; finally, the cap is welded in place. With the type shown in view (b), the sleeve is welded in place first, and the bolt is backed up during riveting over by placing a riveting plug over the end of the bolt. After riveting over, the riveting plug is removed and the cap nut replaced.

The tell-tale holes in flexible staybolts are used to discharge water or steam when the bolts are broken and so indicate a defective bolt; also, they permit the making of a test to detect bolts that are not cracked enough to cause a perceptible discharge. If a test made by an electrical device shows that the hole is clear, the bolt is assumed to be intact. But if the test shows that the hole is obstructed, it is assumed that the bolt is cracked and caused a leak so slight as to be unnoticed at the time but large enough for sediment to fill the hole later.

#### RENEWAL OF LOCOMOTIVE FIREBOXES

**39. Manner of Renewal.**—The manner in which a locomotive firebox is renewed depends to a large extent on the practice followed in the shop. Some shops will attempt to carry out as many boiler repairs as possible without removing the boiler from the locomotive proper, whereas, in other shops, the boiler may be taken off and sent to the boiler shop. Needless to say, the application of a new firebox as a unit will be impossible unless the boiler has been removed from its bed.

**40. Order of Operations.**—When renewing a firebox in its entirety, the staybolts are burned out and various parts of the firebox are removed in sections or as a unit after the mud-ring is taken out. The door sheet, the inside throat sheet, and the back tube-sheet are laid out, flanged, and drilled small in the order given. The laying out can be done from information on the drawings, or templates made from some of the old sheets may be used to aid in locating all of the holes to be drilled. In the case of the flanged sheets, the drilling is done after the flanging has been completed.

The side sheets and the crown sheet are laid out from the drawings or templates and are punched or drilled before being rolled to shape. If the firebox is renewed as a unit, the sections are placed together on the floor and tack-welded at various points. Many fireboxes are entirely butt-welded, while others have the over-lapping flanges riveted. If the firebox is renewed in sections, the back tube-sheet is placed in first, then the side and crown sheet, and then the door sheet, the back end of the boiler being raised just enough to permit each to be placed in proper position. The mud-ring is then lined up and the rivet holes reamed and the rivets applied. The staybolt holes in the roof and side sheets are lined up by means of a long tapered reamer and tap, which, when passed through, not only lines up the holes but also cuts the staybolt thread. The staybolts are then applied and cut off about  $\frac{7}{8}$  inch from each sheet. Next, they are backed up on the inside and riveted over on the outside, and then backed up on the outside and riveted over on the inside. Flexible staybolts, if of the three-piece assembly, are backed up on the outside by placing a little punching under the cap and then turning the cap up tight. After the staybolts are riveted over on the inside, the punching is removed and the welding of the parts is completed. At the line of welding, the sheets are made corrugated or are pulled slightly out of line so that, after the weld cools, the contraction will pull the weld back into normal position, thereby relieving the sheets of the stress that would result if no precautions were taken.

#### EXPANSION OF FIREBOX SHEETS

41. **Difference in Expansion.**—The temperature in the firebox of a properly drafted locomotive approximates 2,000° F. Although the firebox sheets are exposed to a temperature of 2,000° F., the heat is absorbed so rapidly by the water, which, with a pressure of 250 pounds, is at a temperature of 388° F., that the temperature of the sheets, if clean, will not exceed 700° F. But, as the firebox sheets always have a coating of scale of varying thickness, the temperature of the sheets will always be higher than stated. The less scale, the more rapid will be the transfer of heat.

The outside firebox sheets receive all their heat from the water, hence they cannot become heated more than 388° F. Rather, the sheets will be cooler on account of their losing heat by radiation, so there will be a difference of about 300° F. in the temperature of the two sheets. This difference causes the firebox sheets to expand and contract more than the outside sheets and imposes strains on the sheets and the staybolts. The expansion of the firebox sheets is accompanied by a slight bending of the sheets between the staybolts and by a movement of the staybolts into a more or less diagonal position with respect to the sheets.

42. **Effect of Expansion.**—Firebox steel, like other metals, has a definite expansion per inch for each degree increase in temperature. Although the expansion of 1 inch in length would be very small, yet, when the length of the part is considerable, the minute fraction of expansion in each inch will cause an appreciable increase in the length of the whole part. Thus, a locomotive boiler, when fired up, may show a movement at the furnace hearths of more than  $\frac{1}{2}$  inch.

In the case of a box-shaped structure like a firebox, expansion does not affect its length or width to any extent because one sheet resists the movement of the adjoining one, with the result that the accumulated expansion of the sheets meets at the corners and causes a bending of the flanges. For example, the expansion of the side sheets imposes an endwise thrust on the staybolts of the door sheet and the throat steel, or in a direction in which the staybolts are inflexible, so any movement is restricted to the flanges. However, the staybolts in the side sheets will be bent out of their true position during the expansion of the sheets because the direction of the movement is now at right angles to the staybolts.

Similarly, the effect of any expansion sideways of the door sheet and the inside throat sheet on the side sheets will be opposed by the staybolts in these sheets, and the increase in width will be taken care of at the flanges. The bending action at the flanges during expansion and contraction accounts for the cracks that occur frequently at these points in the firebox.

43. **Breaking Zone.**—The term, breaking zone, is applied to the area of the firebox where the movement of the sheets during expansion and contraction is the greatest. This area comprises the ends, sides, and corners of the firebox sheets because it is here that the accumulated expansion of the sheets terminates. The breaking zone is stayed to the outside firebox sheets by flexible staybolts, so the location of this zone can be identified by the arrangement of the staybolts of the flexible type in the adjacent area of the outside sheets.

The expansion of a rectangular sheet of steel, free to expand in all directions, begins at the center and extends in all directions. The expansion is a certain amount for each inch in length, so the sheet will increase in length more than in width, the greatest lengthening being at the four corners because these points are farthest removed from the centers.

At the bottom, the sheets of the firebox, with the exception of the combustion chamber, are riveted to the mud-ring, so that the sheets cannot expand downwards. Instead, beginning near the center, the side sheets will expand front, back, and upward, the maximum movement being at the corners because of the accumulated expansion here. The crown sheet will expand similarly, the greatest movement being at the ends and the least at the sides, where it curves to meet the side sheets. The extreme movement of the side sheets at the ends is taken care of by two vertical rows of flexible staybolts, with a more numerous arrangement at the two upper corners. The upward expansion of the side sheets and the downward expansion of the crown sheet meet where these join; hence about five rows of staybolts in this area are of the flexible type. The progressive expansion of the crown sheet will accumulate at the ends, but the crown staybolts have, on account of their length, sufficient flexibility to permit of this movement without strains. However, the part of the combustion chamber not included in the crown sheet is nearer to the boiler shell than the crown sheet proper, and shorter stays are necessary; hence the staybolts in this area are all of the flexible type.

## DRAFTING OF STEAM LOCOMOTIVES

The following is the report of the Committee on Locomotive Construction, Mechanical Division, Association of American Railroads, which outlines the new standard method of drafting steam locomotives:

### Master Mechanics Locomotive Front End Arrangement

*Recommended Practice*

ADOPTED, 1906; REVISED, 1936

#### FOREWORD

The following is submitted as a discussion and explanation of the proposed new standard method of drafting steam locomotives, based on a proper proportioning to each other of the gas areas over the brick arch and throughout the smokebox as indicated on the enclosed proposed recommended practice, Sheets Nos. 1 and 2. Employing the same general arrangement of the smokebox details and adhering basically to the design known as the "Master Mechanics" Front End, as described in the 1906 "Proceedings of the American Railway Master Mechanics Association," the proposed method has been developed from an analysis of data secured from standing and road test results while redrafting various classes of bituminous coal burning locomotives of conventional design in a wide variety of service and using all the common kinds and mixtures of bituminous coal.

From a study of the gas areas of properly drafted locomotives and observations made while redrafting, it was discovered that there is a definite and necessary relation of these areas to each other and that this relation is practically identical on all of the locomotives redrafted. By virtue of the foregoing it has been considered logical to use one of these areas, namely, the minimum net gas area through the tubes and flues, as an index to which the other gas areas, including the minimum area of the smokestack, should be compared and proportioned.

Comparison of the stack diameters determined by the method herein recommended with the diameters of existing stacks or stack diameters determined by other methods in general use discloses in a majority of cases that larger stacks may be used. The use of larger stacks permits the use of larger exhaust nozzles with subsequent reduction in back pressure. Reduction in back pressure, when accompanied by satisfactory steaming qualities and fire conditions, results in a saving of fuel. Other advantages of reduced back pressure are increased draught pull and a reduction in the general maintenance costs of the locomotive.

While it may appear that this discussion is devoted particularly to an analysis of conditions and re-drafting of existing locomotives, the method outlined is equally applicable to new locomotives, and the designs for the brick arch and smokebox details of a new locomotive may be developed in accordance with same as soon as the minimum net gas area through the tubes and flues is known.

As stated, the details of the smokebox and arrangement of same are in accordance with the "Master Mechanics" front end design and consist of an exhaust stand with round bore exhaust nozzle, smokestack and stack extension bolted together, a diaphragm plate or vertical back deflecting plate, a table plate supported by the exhaust stand and attached to the diaphragm plate and sides of the smokebox, an adjustable draft sheet attached to the table plate, and smokebox netting attached to the table plate and the interior of the smokebox and usually applied in a sloping position.

Inasmuch as the principles and method of drafting recommended herein have been gathered from tests made with locomotives equipped with grates having 20 to 30 per cent effective air opening, it is possible that minor changes in some of the proportions outlined may be necessary in order to obtain satisfactory results when drafting locomotives having grates with net air opening not within the above limits. In such cases it is believed the recommended practice will still serve its primary purpose as a guide. Such changes in the proportions as may be found necessary as a result of thorough tests under the latter conditions should immediately be made a part of the proposed method of drafting. In the event the recommended proportions apply without change to locomotives with grates having other than 20 to 30 per cent effective air opening, this practice should be amended at once to include that fact.

Sheet No. 1 illustrates the recommended arrangement of the smokebox details, with recommended gas areas and other pertinent data. Sheet No. 2 illustrates the recommended brick arch design, together with recommended net area between the back end of the arch and the crown sheet.

The following paragraphs and included diagrams cover the design of the various smokebox details and include a discussion of the analysis of gas areas, gas passages in the smokebox, assembly of smokebox details, study of the drafts and tests to determine locomotive and fuel performance.

**I. Analysis of Smokebox and Firebox Design**

**(a) Calculation and Tabulation of Actual Gas Areas:**

When preparing to re-draft a locomotive or make some changes to improve the steaming qualities, the first step to be taken is to calculate and tabulate the actual gas areas. For convenience these may be calculated in square inches and are as follows:

1. Net area between the top of the brick arch and the crown sheet at the rear end of the arch.
2. Minimum net gas area through the tubes and flues.
3. Maximum area under table plate.
4. Minimum net area under table plate (opposite exhaust stand and steam pipes).
5. Area under draft sheet.
6. Net area through smokebox netting.
7. Area of smokestack at minimum diameter.

**ACTUAL GAS AREAS**  
CHART NO. 1

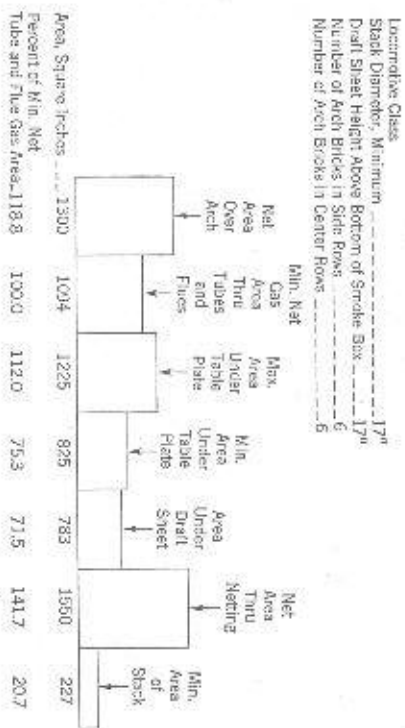

**RECOMMENDED GAS AREAS**  
CHART NO. 2

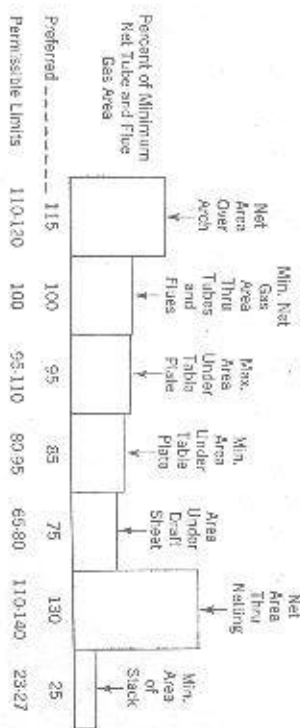

In tabulating the gas areas a simple graphical chart such as Chart No. 1 is recommended. The minimum net gas area through the tubes and flues is used as the base for plotting the other areas and is rated at 100 per cent. A percentage tabulation of the other areas is also given. For convenient reference and comparative purposes each chart should carry any important data such as locomotive classification, size of stack, etc. A typical group of actual gas areas for a U. S. R. A. Mikado type locomotive are shown in Chart No. 1.

(b) Recommended Gas Areas:

The recommended gas areas are illustrated graphically in Chart No. 2 as a percentage of the minimum net gas area through the tubes and flues. The areas shown form the basis of the proposed new method of drafting and have been successfully employed in redrafting several hundreds of locomotives. Many new locomotives drafted to these proportions have been placed in service and operated under varying conditions without any change in the smokebox details.

In Chart No. 2 it will be noted that there is a gradual stepping down in the preferred areas from the area over the arch to the area under the draft sheet. While this condition is ideal it will be found necessary in some cases to have the maximum area under the table plate somewhat in excess of the minimum net gas area through the tubes and flues in order that the minimum area under the table plate shall not be less than the area under the draft sheet. Where the latter condition exists it has been found that the draft sheet loses the most of its value as a regulator of the drafts.

Application of the recommended proportions to the locomotive for which the actual gas areas are tabulated in Chart No. 1 permitted an increase in the stack diameter from 17 in. to 20 in. This, in turn, made it possible to increase the exhaust nozzle diameter from 7 in. to 8 in. with entirely satisfactory results and with a substantial saving in fuel.

(c) Important Gas Passages in Smokebox:

1. Space Between Front Flue Sheet and Diaphragm Plate:

Not infrequently on some of the older designs of locomotives it is found that the diaphragm plate is less than 30 in. ahead of the front flue sheet. This condition is usually responsible for and accompanied by excessive heat at the firebox. In exaggerated cases the flames in the firebox have a tendency to roll and not move freely over the brick arch.

In all cases where the diaphragm plate is less than 30 in. ahead of the front flue sheet it is recommended that the diaphragm be sloped forward at the bottom from a point in line with the bottom of the superheater header. The total amount of slope will usually be determined by the distance between the exhaust stand and the diaphragm and should not exceed 15 in. In cases where the flare of the smoke-

stack interferes with obtaining the desired slope in the diaphragm a small portion may be cut off the stack flare without harmful effects. The portion of table plate projecting backward beyond the new location of the diaphragm plate should be cut off. A diagram illustrating a sloped diaphragm plate is shown in Figure 1.

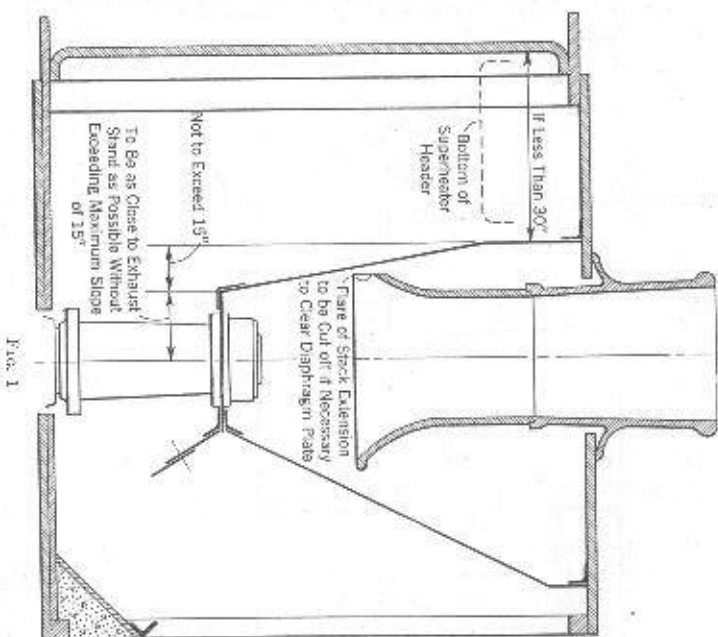

On some of the more modern designs of locomotives the reverse of the foregoing condition is encountered, and the diaphragm plate is an excessive distance from the front flue sheet. With some of the smaller locomotives this condition may be responsible for the difficulty in obtaining sufficient draft on the fire. Where such an effect is recognized it has been found helpful to install an additional diaphragm plate in back of the existing plate and approximately 36 in. ahead of the front flue sheet. The table plate should be extended over to the extra diaphragm and the compartment thus formed made perfectly air tight. The application of the additional diaphragm is illustrated in Figure 2. The superheater damper, on locomotives equipped with same, is

located in the passage between the front fire sheet and diaphragm plate. Some railroads have removed all superheater dampers while others have retained them. It is not intended in this discussion to approve or criticize either practice. However, it has been noted that drafting of

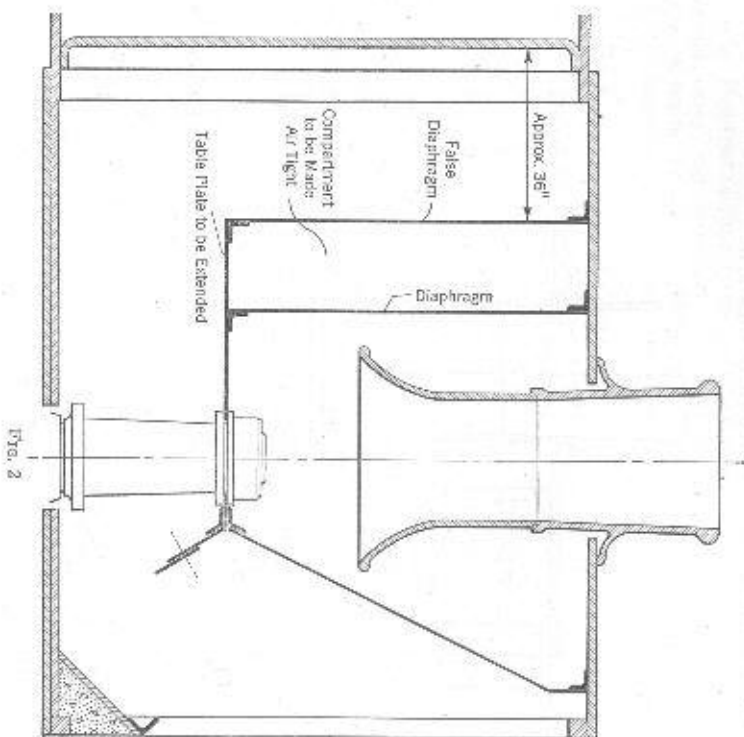

Fig. 2

locomotives by the method herein described has been much more successful when the dampers have been removed. All accompanying diagrams have been prepared on that basis.

#### 2. Space Between Diaphragm Plate and Back of Stack:

The space in back of the stack may also be excessive, although this is not as likely to be responsible for poor steaming qualities as excessive space behind the diaphragm. On smaller power, however, if the existing diaphragm is more than 12 in. behind the back side of the stack some improvement may be noted if an additional diaphragm plate is applied as close to the smokestack as possible. The compartment thus formed should be made perfectly air tight. A diagram illustrating the additional diaphragm is shown in Figure 3.

#### 3. Space Between Front Edge of Draft Sheet and Smokebox Front:

The space between the front edge of the draft sheet and the smokebox front is very important, and in no case should the area between the draft sheet and the smokebox front be less than the area under the draft sheet. It is preferred to have the table plate extend forward from

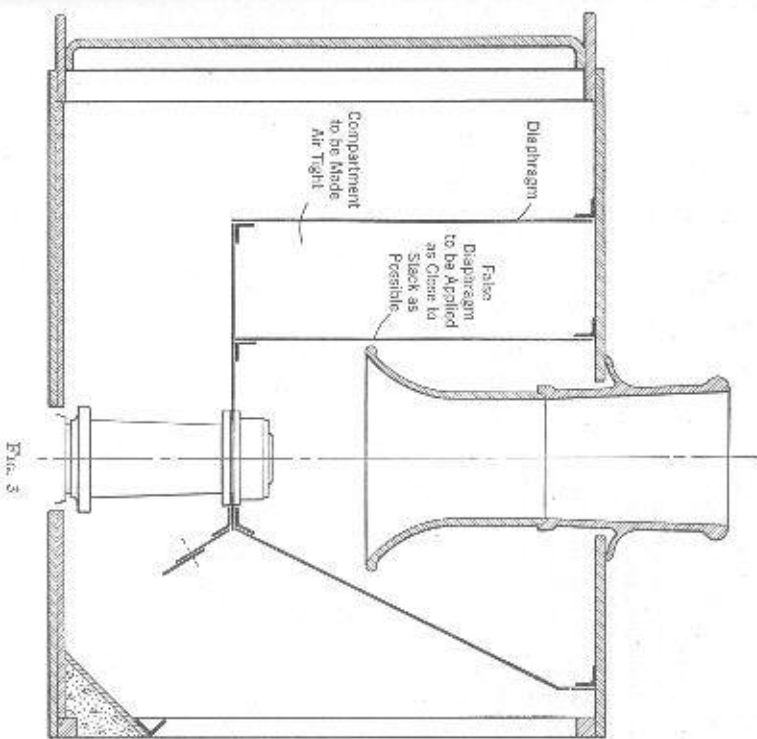

Fig. 3

the center of the exhaust stand as little as possible, providing only sufficient plate to attach the smokebox netting and the draft sheet.

#### 4. Space Below Table Plate:

Too much attention cannot be given to keeping the space below the table plate free from any obstructions which may hinder the free flow of gases from the firebox. The presence of large pipes, such as the booster exhaust or pipes connecting the exhaust stand or exhaust passages of the cylinder to the feedwater heater, particularly when

located on the floor of the smokebox, are bound to set up eddies in the flow of gases and may be responsible for undesirable fire conditions and poor steaming. The injurious effects of these pipes may exist even though the net area under the table plate, deducting the areas of the pipes, may be well within the recommended limits. Every attempt should be made to remove these pipes from the smokebox entirely. If it is impractical or impossible to do this, the pipes should be applied directly under and close to the table plate or placed in line with the exhaust stand in order to offer as little resistance as possible to the gas flow.

In some cases it will be found that main steam pipe casings within the smokebox are unnecessarily large, making it difficult to obtain the recommended minimum area under the table plate. Extra large steam pipe casings may also have an undesirable effect on the fire by creating eddies in the flow of gases from the firebox. When these conditions exist it is recommended that the size of the steam pipe casings be reduced in order to secure the desired minimum area, rather than raising the table plate for this purpose. However, in no case should the minimum area under the table plate be less than the minimum recommended on Sheet No. 1.

#### (d) Design of Brick Arch:

The importance of the brick arch construction is emphasized since it plays a most important part in the combustion process. The net area over the arch at the rear end should be within the limits recommended in Chart No. 2 in order to provide ample space for the passage of the gases of combustion and yet confine the stack loss to a minimum. Care should be taken to see that the arch is free from holes of any kind. For best results the arch should be sealed at the throat sheet. The use of "Loe" brick at the throat sheet is usually accompanied by and accountable for excessive stack loss, smoke and unequal draft distribution.

### II. Recommended Design of Smokebox Details

#### (a) Smokestack:

The diameter of the smokestack will be obtained from Chart No. 2, using that dimension which, in even inches, provides an area closest to that recommended. It should be understood that this will be the minimum diameter or the diameter of the stack at the choke.

A two-piece smokestack, consisting of the stack proper and stack extension, is recommended. The stack proper should have a tapered bore throughout its length, the taper being 1 in. in diameter in 15 in. of length. While this taper is preferred, satisfactory results may be obtained with stacks having a taper of 1 in. in diameter in 12 in. of length. However, it is recommended that the stack taper be kept

within these limits, namely, 1 in. in diameter in 12 in. to 15 in. of length. Where the locomotive design permits, it is recommended that the entire length of the stack proper be made 30 in.

The stack extension should have a parallel bore equal to the minimum bore of the stack and end in a flange 28 in. to 32 in. in diameter,

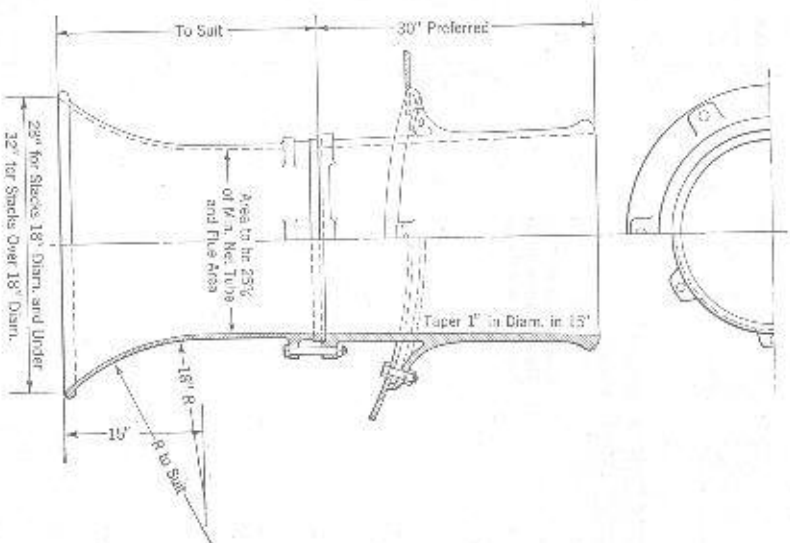

Fig. 4

depending on the size of the stack. The flare should be approximately 15 in. in length and be designed with a long sweeping curved surface. The length of the stack extension will be determined by other conditions and should be such as to provide a space 15 in. to 16 in. in height between the top of the exhaust nozzle and the bottom of the stack extension. Figure 4 illustrates the recommended design of stack and stack extension.

## (b) Exhaust Stand:

Figure 5 illustrates the recommended design of exhaust stand. It will be noted that no provision is made for expansion of the exhaust steam within the exhaust stand as has been done in some designs. The barrel of the exhaust stand should taper directly from the rectangular

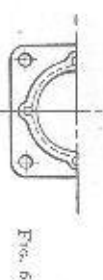

FIG. 5

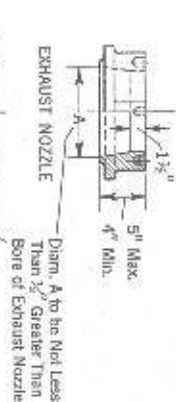

FIG. 6

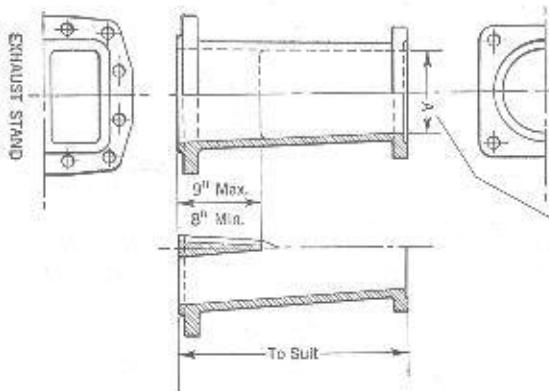

FIG. 5

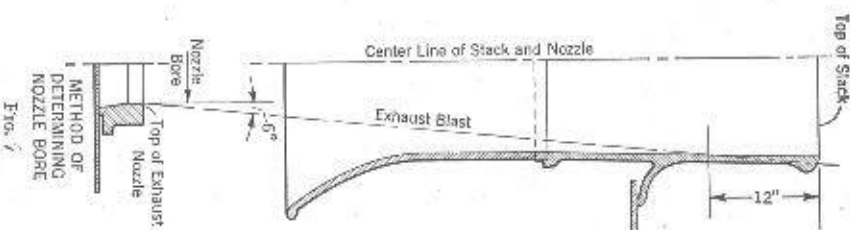

FIG. 7

shape at the bottom to the cylindrical at the top. The parting rib in the bottom of the stand should be 8 in. to 9 in. in height. The design illustrated is applicable only to two-cylinder locomotives.

Attention is directed to the note on Figure 5 stating that the bore of the exhaust stand at the top should never be less than  $\frac{1}{2}$  in. greater than the bore of the maximum diameter exhaust nozzle used.

In some cases the supply of exhaust steam for the feedwater heater is taken from the exhaust stand. This practice is not recommended as it affords an additional source of steam leaks within the smokebox. Furthermore, the pipes applied for conveying the exhaust steam to the heater, when applied below the table plate, very often offer serious restriction to the free flow of gases. It is much preferred that these pipes be connected to the exhaust passages of the cylinders and connected with the feedwater heater either entirely outside of the smokebox or in depressions built into and sealed from the smokebox.

## (c) Exhaust Nozzle:

Experiments have been in progress for many years to develop the "perfect" exhaust nozzle. As a result there are several exhaust nozzles of radically different design in use at the present time. The most recent experiments along this line were those conducted at the University of Illinois by Professor Young. In his tests practically all designs of exhaust nozzles now in use were tried and the efficiency of each determined by its ability to provide a steam jet which would entrain the greatest volume of air. It was determined by Professor Young that the ordinary round bore nozzle, when provided with some sort of a spreader or bridge to roughen the steam jet, is, for all practical purposes, the equal of any other type of nozzle.

Because of its simplicity of construction and widespread use, as well as its proved efficiency, the round bore exhaust nozzle is recommended. Figure 6 illustrates the recommended design. No provision for the blower is made in the nozzle. The bore of the nozzle should be parallel for approximately  $1\frac{1}{2}$  in., and the total height of the nozzle, 4 in. to 5 in. The bore of the nozzle at the junction with the exhaust stand should never be less than  $\frac{1}{2}$  in. greater than the bore of the largest diameter exhaust nozzle used.

In determining the correct bore of the exhaust nozzle the theoretical shape of the exhaust steam blast and the point on the stack bore at which it is desired to have the exhaust blast make its "seal" must be taken into consideration. It has been found by tests with round bore exhaust nozzles equipped with square bar across spreaders that the exhaust steam leaves the nozzle at an angle of approximately six degrees when exhausted at normal working back pressures of 8 to 10 pounds. It has also been observed that best results are obtained when the theoretical "seal" of the exhaust steam jet with the bore of the stack is at a point approximately 12 in. below the top of the stack.

From the foregoing the bore of the exhaust nozzle is determined as follows and is illustrated diagrammatically in Figure 7.

Make a layout showing the inside surface of the stack. In its correct relation to the top of the stack draw a line representing the top of the exhaust nozzle. From a line parallel to the top of the stack and intersecting the stack bore at a distance of 12 in. from the top of the

stack project two lines, each at an angle of six degrees from the vertical, to intersect the line representing the top of the exhaust nozzle. The distance between these lines, measured on the top of the nozzle, will be the recommended bore of the nozzle. For practical reasons the nozzle should be bored to the nearest even dimension in quarter inches. When making changes in the bore of the exhaust nozzle in order to improve steaming qualities, it is suggested that increases or decreases in the bore be made in increments of one quarter inch with nozzles of 8 in. bore and over. For nozzles under 8 in. bore the changes should be made in increments of one-eighth inch.

**(d) Exhaust Nozzle Spreader:**

In the course of the tests made while refraining locomotives various types of exhaust nozzle spreaders or bridges were tried. Those included the square bar cross spreader, the basket bridge, the single bar spreader, and the Goodfellow prongs. Tests were also made with an open nozzle, but without notable success except on yard engines in comparatively light service.

By far the most satisfactory results were obtained with the square bar cross spreader, and this type is recommended. In making the square bar spreader the diagonals of the cross section of the bar are perpendicular and horizontal. The recommended design is shown in Figure 8.

The size of the bar to be used for the spreader depends largely on the size of the nozzle, although there is no fixed rule on this. Based on the nozzle bore, the suggested sizes of the bar for cross spreader are as follows:

Nozzle Bore	Size of Square Bar for Cross Spreader
5" to 6 $\frac{1}{2}$ "	$\frac{3}{8}$ "
7" to 7 $\frac{1}{2}$ "	$\frac{7}{16}$ "
8" to 8 $\frac{1}{2}$ "	$\frac{1}{2}$ "
9" and above	$\frac{5}{8}$ "

Where satisfactory steaming qualities and fire conditions can be obtained by so doing, it is recommended that the cross spreader rest on top of the nozzle. However, in the course of drafting certain locomotives it may be found that improvement in the fire conditions can be made by setting the bottom edge of the cross spreader  $\frac{1}{4}$  in. or  $\frac{3}{8}$  in. below and into the top of the nozzle. Likewise, in some cases it may be found that a change in the size of the bar in the spreader will prove of great benefit.

**(e) The Blower:**

In many instances too little attention has been given to the blower design, although the blower is used innumerable times and for indefi-

nite periods during each day's service of the ordinary steam locomotive. An inefficient blower is wasteful of fuel as well as being unsatisfactory as a draft producing device.

Because of its effectiveness in filling the stack and creating draft, and because of the simplicity of construction, the "ring" type blower, made of ordinary 1 $\frac{1}{2}$  in. pipe, is recommended. Figure 9 illustrates the details of the design and the recommended application of the blower.

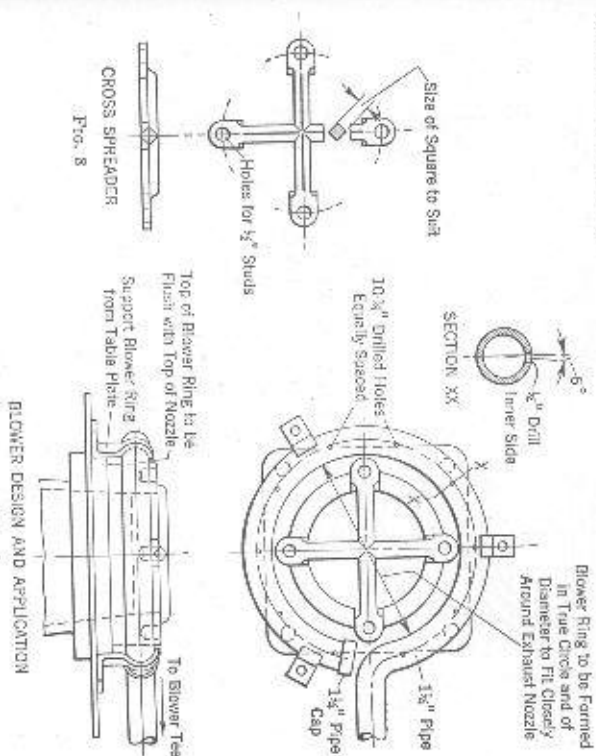

FIG. 9

**(f) Design and Application of Draft Sheet:**

The draft sheet should be securely bolted to an angle or plate attached to the front end of the table plate and should fit neatly against the sides of the smokebox. While it is recommended that this sheet be applied at an angle of 30 degrees from the vertical, better results are secured in some cases when it is set at a greater or lesser angle than 30 degrees. The bottom edge of the draft sheet should be perfectly straight and perpendicular to the vertical center line of the boiler. A typical application is illustrated on Sheet No. 1.

**(g) Deflecting Plate in Bottom of Smokebox:**

A deflecting plate applied at an angle of 45 degrees in the bottom of the smokebox, as illustrated on Sheet No. 1, is recommended because of its protective value to the smokebox front and because it serves to prevent cinder accumulation at this point. Application of an angle



### III. Assembly of Smokebox Details

#### (a) Typical Recommended Arrangement:

Sheet No. 1 illustrates a smokebox and Sheet No. 2 an arch brick arrangement prepared in accordance with the recommendations outlined herein. For convenient reference the recommended gas areas are also shown, together with other pertinent data mentioned elsewhere in this discussion.

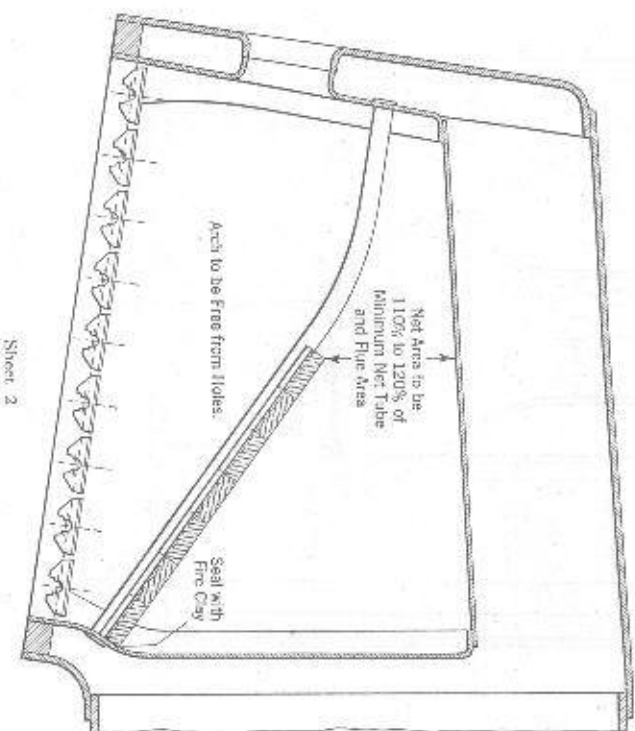

#### (b) Points to Be Observed in Assembly of Smokebox Details:

Too much care cannot be taken in assembling the various smokebox details if the utmost efficiency is to be realized. It is particularly essential that there be perfect alignment of the stack and exhaust nozzle. All plates should be applied exactly in accordance with the drawings. The diaphragm plate, table plate and draft sheet should be tight and free from holes.

#### (c) Test for Steam Leaks:

After applying the exhaust stand a hydrostatic test should be applied. The joints between the exhaust stand and cylinder, and between

the exhaust nozzle and stand should be made perfectly tight during this test. Superheater units should be observed for leaks and tightened if necessary. All pipe joints in the smokebox must be made absolutely tight. Steam leaks in the smokebox can offset the most capable efforts to make a locomotive steam properly and lead to incorrect analyses of the fire conditions.

#### (d) Test for Air Leaks:

Air leaks, like steam leaks, are responsible for much of the difficulty encountered in obtaining and maintaining good steaming qualities and economical fuel performance.

A simple test for disclosing air leaks in the front end is known as the "smoke" test and is conducted as follows: Place a cover over the entire top of the stack and then throw a quantity of coal on the fire. All air leaks of consequence will be indicated by the escaping smoke.

### IV. Discussion of the Drafts

#### (a) Drafts of Most Significance:

While it is not necessary to know and record the actual drafts obtained in the combustion area and smokebox in order to satisfactorily draft or redraft a locomotive, this information forms a valuable record, especially where an extensive program of redrafting is undertaken.

Due to the difficulty of securing accurate readings of firebox and ashpan drafts on the road, these drafts are given no further consideration in this discussion. If it is desired to obtain a record of these drafts it is recommended that standing tests be made.

Smokebox drafts can be readily obtained in road service and furnish all the data necessary for comparing the effects on the drafts brought about by redrafting. The smokebox drafts of most significance are those taken at the following location in the smokebox: Above and below the table plate at a point just in back of the junction between the smokebox setting and the table plate, and in back of the diaphragm at a point approximately on the horizontal center line of the smokebox. Draft gage gages applied at the above positions should extend in to the vertical center line of the smokebox with the inner end of each pipe capped and provided with six staggered  $\frac{1}{8}$  in. drilled holes within a space of four inches from the capped end. The draft gage pipes may be extended to a draft gage panel in the cab thus providing safe, convenient reading of the drafts. One-quarter inch pipe is satisfactory for draft gage pipe.

#### (b) Plotting of Draft Curves:

Draft readings should be plotted as illustrated in Figure 11, plotting draft in inches of water against back pressure in pounds. It has been

found helpful when plotting comparative draft curves to illustrate the effect of various smokebox changes to plot the draft at only one position in the smokebox on one sheet. A composite draft sheet such as shown in Figure 11, illustrating the drafts at all three positions in the smokebox, should be prepared for record after changes to develop satisfactory steaming qualities and fire conditions have been completed. Draft curves for the original smokebox arrangement should be plotted in order to determine and compare the exact effect of the modified smokebox arrangement on the drafts.

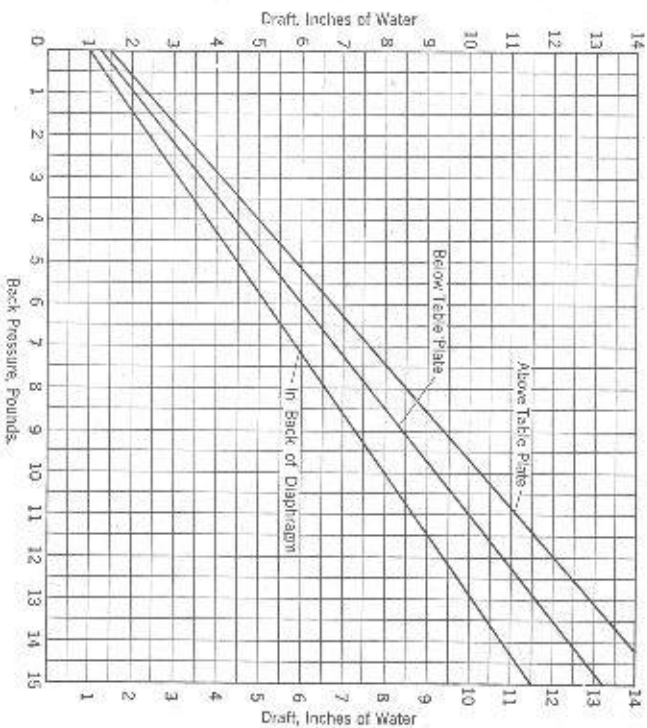

FIG. 11

### (c) Analysis of the Draft Curves:

It will be noted that the draft curves illustrated in Figure 11 are straight lines with practically the same "falling off" in the drafts from the draft above the table plate to the draft in back of the diaphragm. While the latter condition is ideal it cannot always be obtained due to limitations of design and the impossibility of obtaining the preferred proportional gas areas. It should be possible, however, to obtain draft curves represented by straight lines from any locomotive which is properly drafted. Draft curves which fall off in the upper back pressure

ranges indicate improper seal of the exhaust blast in the stack. This fact may account for smoke or other undesirable fire conditions when working the locomotive at its maximum output.

A brief explanation of the draft curves plotted in Figure 11 is offered at this point. It will be observed on these curves that some draft is indicated at zero pounds of back pressure. This condition will be found to exist in all cases where locomotives are re-drafted in accordance with these principles. Due to the increase in the nozzle bore, back pressure will not be indicated on the gage until the steam chest pressure is from 25 to 50 pounds or higher, depending on the nozzle bore. This is probably due to the lack of sensitiveness of the ordinary back pressure gage. Draft is indicated on the draft gages, however, whenever steam is exhausted from the cylinders, regardless of the amount of steam chest pressure. The drafts illustrated in Figure 11 at zero pounds back pressure were taken at the point back pressure was about to register on the gage.

### (d) Necessary Amount of Draft:

While no attempt should be made to state definitely how much draft is necessary to produce satisfactory steaming qualities, with good fire and stack conditions, it has been observed on a large number of locomotives, re-drafted in accordance with these principles, that the best performance has been obtained when the draft in back of the diaphragm in inches of water is approximately eight-tenths of the back pressure in pounds in the normal working range of the locomotive, considered at eight to ten pounds back pressure. This figure is empirical and is offered for its possible value as a guide.

In summary it is considered advisable to state that each class of locomotives should have only sufficient draft to burn the fire satisfactorily under all operating conditions with free steaming qualities and without smoke. Excessive drafts are to be avoided as they are largely responsible for excessive stack loss and under-cutting of staybolts, the sheets and various smokebox details.

## V. Locomotive and Fuel Performance Tests to Determine Advantages Due to Redrafting

### (a) Standing Tests:

Extensive use of the standing test was resorted to during the early experiments in re-drafting and assembling the data upon which this practice is based. The standing tests made it possible to quickly make the changes needed to produce satisfactory steaming qualities and provide information of inestimable value in arriving at the proportions recommended herein.

These proportions and principles of front end design have proved so reliable that a great number of locomotives, re-drafted in accordance

with them, have been placed in revenue service without preliminary trial. Only minor changes have been required to produce altogether satisfactory steaming qualities and stack conditions. These changes have been made without loss of time to the locomotive in any instance. It is also worthy of note that in no case has a steam failure occurred while re-drafting a locomotive. In view of this, steaming tests for the purpose of re-drafting are not considered necessary and are not recommended.

(b) Dynamometer Car Tests:

Where a Dynamometer Car is available, accurate information on the improvement made in a locomotive by re-drafting may be obtained by making a series of comparative tests before and after re-drafting. In making such tests a division should be chosen which will provide the most consistent operation from the standpoint of tonnage and speed, and with a minimum of drifting distance. In many cases it is preferable to make the tests over only that portion of a division providing the desired conditions, thus eliminating many of the variables which affect the locomotive performance. It is always preferable to make the tests with the standard or original smokebox arrangement first, making sufficient tests to obtain accurate average results.

Tests with the re-drafted engine to secure comparative data should not be started until it is reasonably certain that the steaming qualities and stack conditions are the best that can be obtained.

On all such tests made with the Dynamometer Car the coal should be weighed and water measured. The locomotive should be equipped with a back pressure gage, steam chest pressure gage, steam pyrometer and draft gages. The reverse gear should be calibrated. Gage readings may be taken at mileposts or at specified intervals of time. The usual dynamometer data should also be recorded. All of this information is essential to determine the actual benefits of re-drafting and affords very interesting data for permanent record and study.

In making comparative fuel performance tests it is very essential that the locomotive be worked at the same capacity on all the tests. Maintaining an equal average drawbar horsepower on tests with the locomotive before and after re-drafting assures results which can safely be compared, providing this equal drawbar horsepower is obtained with fairly equal average speeds in each case. The coal per drawbar horsepower hour should be used to measure the locomotive fuel performance.

Dynamometer tests may also be conducted to determine the comparative ability of the original and re-drafted locomotive to handle trains. In such tests the increased tonnage hauled by the re-drafted locomotive or the reduction in running time over the division with equal tonnage will afford comparative data. On tests of this nature in which the average drawbar horsepower of the re-drafted locomotive will be higher than that of the locomotive before re-drafting, it may also

happen that the coal per drawbar horsepower hour of the re-drafted locomotive will equal or even exceed that for the locomotive before re-drafting. This will be governed very largely by the actual improvement in the fire conditions and the amount of reduction in back pressure brought about by re-drafting and the amount of the increase in speed or tonnage, or a combination of both, of the re-drafted over the original locomotive.

(c) Road Tests Without Dynamometer Car (Observation Tests):

Road tests to determine comparative fuel performance of a re-drafted locomotive, when made without a Dynamometer Car and where coal per 1000 gross ton miles is used as a basis for comparison, are of no particular value, and may often be very misleading, even though the coal may be weighed on such tests. While tonnage and average speed may be kept comparable there are other uncontrollable factors entering in, which may affect the coal consumption and the locomotive performance generally.

Increase in tonnage or speed for the re-drafted locomotive may be determined without the use of a Dynamometer Car. Tests or trial runs for this purpose should certainly be made in order that the advantages in this respect, brought about by re-drafting, may be utilized. Whenever tests of this nature are conducted without a Dynamometer Car it is recommended that cab gage readings, including the draft readings and cut-off, be taken as on dynamometer tests. The data secured will prove of considerable value.

VI. Conclusion

Although in some cases immediate improvements in the fuel and general performance of a locomotive may be obtained by making partial changes in line with these recommendations, the greatest success from an application of the foregoing principles of drafting can be realized only when the procedure indicated is carried out in its entirety as outlined.

# LOCOMOTIVE BOILERS

Serial 1967 D

(PART 2)

Edition 2

## CONSTRUCTION, DETAILS, AND MAINTENANCE (Continued)

### FIREBOX APPLIANCES

#### PURPOSE

1. The purpose of the different appliances that are installed in the fireboxes of modern locomotive boilers is to secure either a more complete burning of the fuel, or a more rapid circulation of water around the firebox and thereby a quicker generation of steam. These appliances comprise firebrick arches, combustion chambers, arch tubes, and thermic syphons.

#### ARCH TUBES

2. An arch tube is an iron or steel tube, 3 to 3½ inches in diameter, that is used to promote the circulation of the water around the firebox and to support the brick arch.

The arch tubes *k* are shown in the firebox in Fig. 1, in which the back head of the boiler, the roof sheet, and the outside firebox sheets are omitted, the sheets shown being the two inside firebox sheets, the tube sheet, and a part of the door sheet. One end of the tube *k* is inserted in the door sheet *f<sub>2</sub>*, and the other end, when a combustion chamber is used, is connected to the inside, or firebox, throat sheet. When a combustion chamber is not used, the front ends of the arch tubes are inserted in the tube-sheet below the tubes.

Arch tubes promote the circulation of the water, because the front ends of the tubes are in such a position that they receive the water from a point at the bottom of the boiler shell where

it is comparatively cool. The water in the arch tubes evaporates very rapidly and is replaced by the cooler water which enters the tubes at their front ends, the result being a strong flow of water, as indicated by the arrows in Fig. 2. The rapid flow of the water tends to make the other heating surfaces more effective. The number of arch tubes that are used varies from two to six, depending on the width of the firebox, and they are so placed that the firebrick will fit snugly on the top of them.

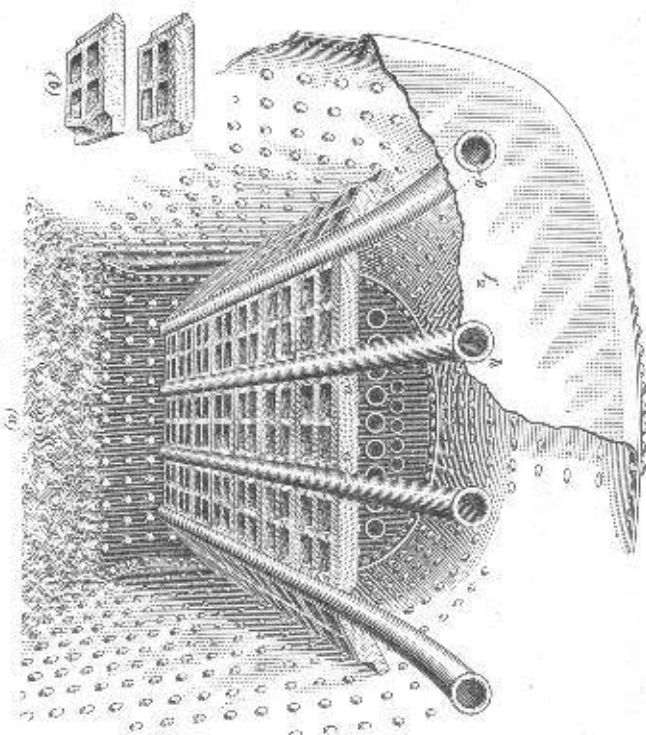

FIG. 1

3. Application.—The method of applying the arch tubes to the firebox sheets is shown in Fig. 2, in which *J*<sub>1</sub> indicates the crown-sheet, *f*<sub>2</sub> the door sheet, *f*<sub>3</sub> the inside throat sheet, *b* the back head, and *l* the throat sheet. The holes in the firebox sheets are drilled  $\frac{3}{8}$  inch larger in diameter than the arch tube, so that it can be easily applied. The tubes are then bent to the required shape and cut to length. From  $\frac{1}{2}$  to  $\frac{3}{4}$  inch of the tube is allowed to project into the water space so as to provide material for

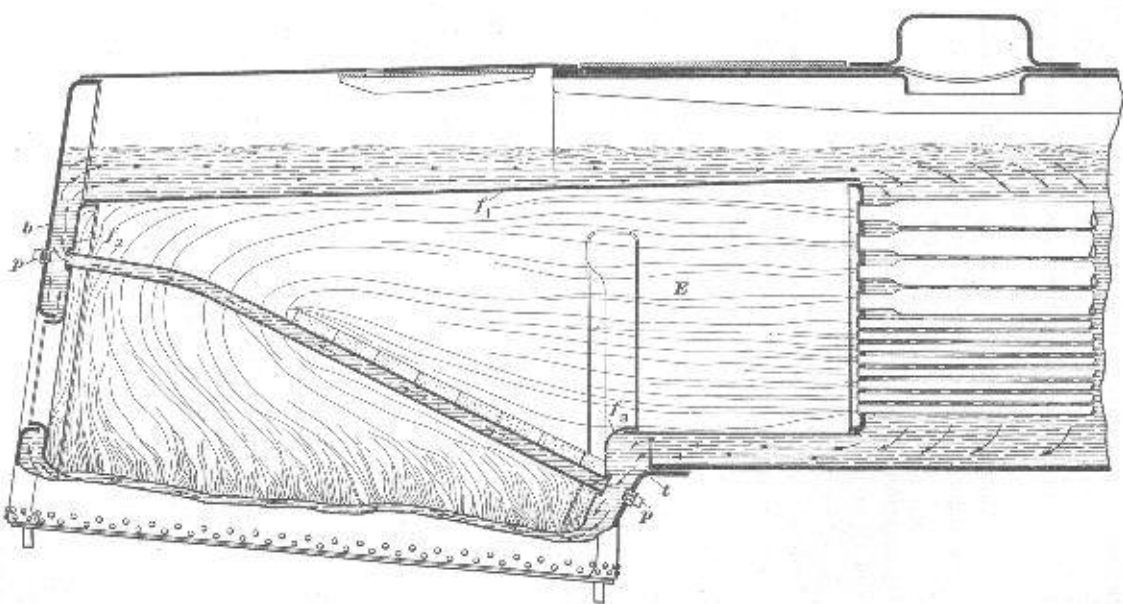

FIG. 2

beading over as shown in Fig. 3, which is an enlarged view of the back end of an arch tube, and an arch-tube plug.

Arch-tube plugs *p*, Fig. 2, are inserted in the back head *b* and throat sheet *t* so as to provide a means whereby the tubes can be rolled and beaded and also to give access for cleaning. The plugs are of standard taper,  $\frac{3}{4}$  inch in 12 inches, and twelve threads per inch.

#### FIREBRICK ARCH

**4. Description.**—As the name indicates, the firebrick arch consists of an arch of firebrick, built up in sections and set in the firebox in an inclined position.

The firebrick arch is applied for two principal reasons, first to aid combustion and so save fuel, and second to increase the life of the flues by reducing flue leakage.

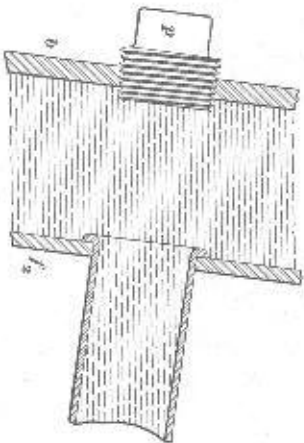

FIG. 3

In Fig. 1 (*a*) is shown a firebrick arch installed in a wide firebox, as seen from the firebox door. The ends of the bricks at *a* are shaped to fit the point where they rest on the arch tubes *k*. Next to the side sheets, the bricks rest against the sheets. The surfaces of the bricks exposed to the fire are dislaced out as shown. This construction retards the passage of the gases along the arch and so causes them to mix more completely with the air. An opening is left at the back end of the arch below the crown-sheet to allow the gases to pass to the tubes. View (*b*) shows two of the firebricks removed from the arch. The lower brick is one that is placed along the side of the firebox, and the upper one is a middle brick.

The position of the brick arch divides the firebox into two sections; one below the arch, in which the fuel is consumed, and the other above the arch, which acts as a combustion chamber in case no other one is provided, and as an extension of the combustion chamber when there is one. The arch is extended back until the opening between the top of the arch and the crown-sheet is equivalent to about 11.5 per cent. of the total flue area.

**5. Position of Arch at Tube-Sheet.**—The ideal method of setting brick arches is to place them tight against the tube-sheet. In this position, the tubes and flues receive the most protection from the currents of cold air that may enter through the grates at the front end of the firebox.

The claim is sometimes made that with a closed arch, or one set tight against the flue sheet, the fine coal would lodge on top of the arch and tend to plug the lower flues, whereas with an opening between the arch and the sheet the draft through the opening would carry the coal through the flues without stopping them up. This in a measure is correct, but an open arch would have serious drawbacks. Tests have shown that the draft with an open arch is twice as great immediately under the opening than at any other part of the firebox. The effect is that the finer particles of coal at that point are lifted up and carried out of the stack unburned. Also, with a dead fire under the opening, the cold air is drawn through directly into the bottom flues and causes them to leak.

With a closed arch, regardless of the position of the damper in the smokebox, the draft is weakest at the front of the firebox and strengthens progressively toward the rear. This is caused by the fact that the arch has a gradual slope upwards from the front toward the rear of the firebox, the opening between the arch and the door sheet accounting for the greater draft on the back section of grates.

To equalize the draft, installations have been made, in some cases, of grates with a greater percentage of air openings in the front ones than in the rear.

**6. Advantages of Firebrick Arch.**—The advantages of the firebrick arch are: (1) It lengthens the path of the hot gases

to the tubes and assures the more intimate mixing of the gases by surface friction and consequent turbulence; (2) it constitutes a reservoir from which heat is radiated to the firebed when the latter is cooled by the addition of fuel, that is, the brick arch serves as a radiation screen, the temperature of the lower surface of the brick being maintained sufficiently high for this purpose by the heat transferred thereto by radiation from the incandescent fuel below it. The greater part of the heat from the firebed therefore is returned to the fuel by radiation, thus maintaining the temperature of combustion.

#### COMBUSTION CHAMBER

**7. Description.**—The combustion chamber *F*, Fig. 2, is a compartment or space in a locomotive boiler, between the firebox and the back tube-sheet, and is really an extension of the firebox forward of the grates; it may vary in length from 6 inches to 6 or 7 feet, depending on the size and capacity of the boiler.

The combustion chamber is formed by lengthening the firebox sheets and extending them beyond the mud-ring; this portion of the firebox then becomes more or less circular, as shown in Fig. 4. In order to connect the rectangular portion of the firebox, which is riveted to the sides and back of the mud-ring, to the circular portion that extends beyond it, an inside throat sheet of the shape shown must be employed. At the front, this sheet is riveted at the bottom to the inside of the mud-ring, the sides are riveted to the firebox proper, and the top flange is riveted to the part of the firebox that forms the combustion chamber.

The type of combustion chamber shown is known, on account of its appearance, as the barrel, or built-in, combustion chamber. When the tube-sheet is directly in front of the grates, the space above the brick arch is sometimes referred to as the combustion chamber. The use of combustion chambers requires a large number of additional staybolts and therefore more attention must be given them. The installation of flexible staybolts properly applied will prevent much of the staybolt trouble in combustion chambers.

**8. Advantages.**—The surface of the firebox evaporates about five times as much water per square foot as does the surface of the tubes. Therefore, the advantage of the combustion chamber is that it gives more firebox heating surface and a greater evaporation with a specified grate area. The use of a combustion chamber in large boilers also permits the use of shorter tubes. Tubes of an excessive length cause the draft to

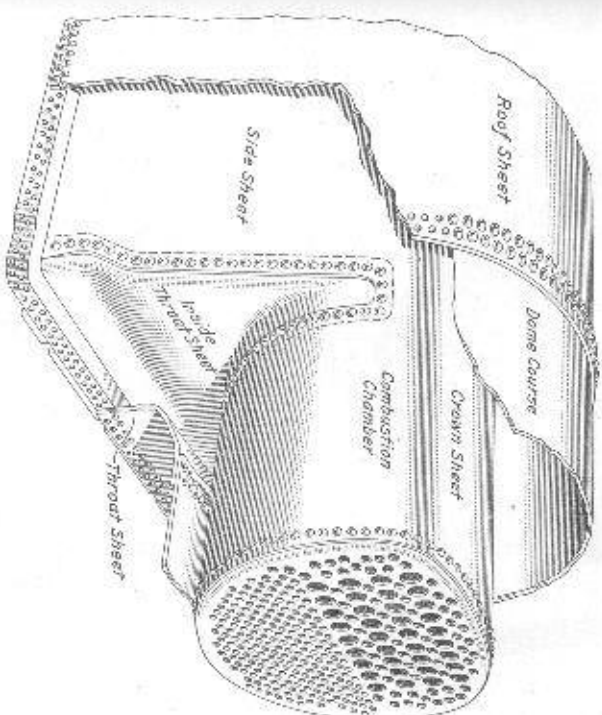

FIG. 4

lag at their front ends. With a combustion chamber the gases have to travel farther before they enter the tubes and they therefore have a better chance of being thoroughly burned than if a combustion chamber is not used.

#### THERMIC SYPHONS

**9. Purpose.**—A thermic syphon may be considered as a special type of arch tube. Two or three may be installed in the firebox; Fig. 5 shows a two-syphon application, and one is often placed in the combustion chamber. One end of the syphon *s* is

inserted in a diaphragm *h* welded to the inside throat sheet *i*, and the other end connects to the crown-sheet in which an opening is cut to correspond to the opening *s*<sub>2</sub> in the syphon.

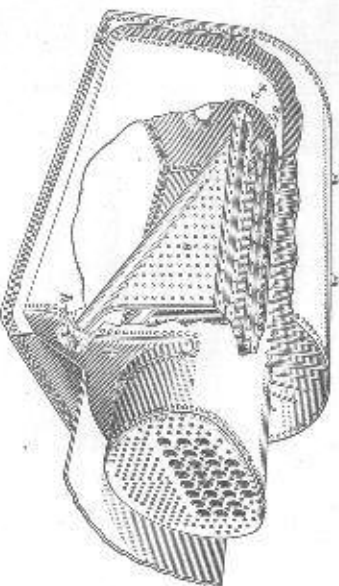

FIG. 5

The function of the syphons is to stimulate and accelerate the circulation of the water in the boiler and hence increase the rate at which the water is being evaporated into steam. An increase

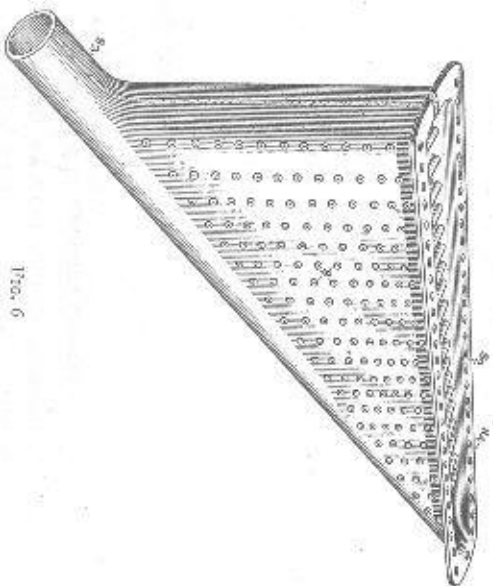

FIG. 6

in the evaporation rate results in the development of a greater drawbar pull at speed; that is, the boiler horsepower is increased.

The syphons also not only provide additional and highly effective heating surface, but also prevent excessive damage to the crown-sheet in cases of low water. The upward circulation through the syphons deposits water on the crown-sheet after the general water level has receded below it, and this limits the rupture to a smaller area than otherwise.

**10. Construction.**—An exterior view of a thermic syphon is shown in Fig. 6. It is made from an approximately square plate of 3-inch firebox steel folded over a 6½-inch mandrel along a diagonal in such a manner as to form a triangular water leg.

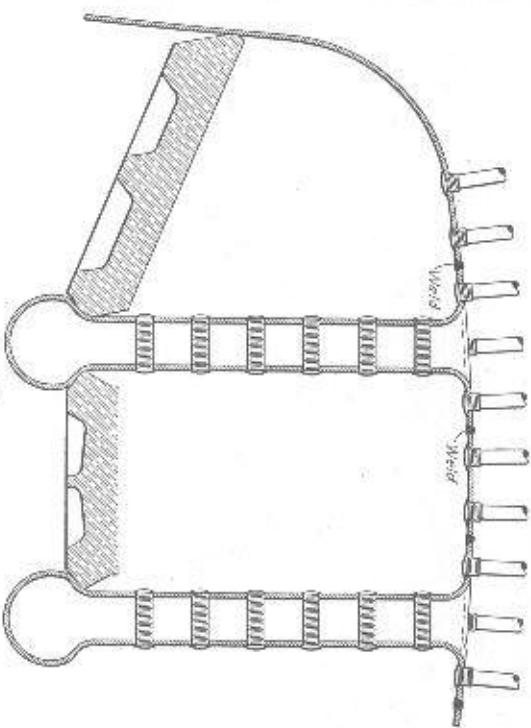

FIG. 7

The sides that are drawn together sufficiently to provide a water space 3 inches wide, are supported by staybolts in the ordinary manner. The bottom or channel portion *s*<sub>2</sub> of the syphon, being circular, is self-supporting and is extended to form a cylindrical intake neck 6½ inches in diameter. The vertical edges of the sheet are flanged inwardly and are joined by autogenous welding. The welded seam extends from the top of the syphon down to the end of the neck and is supported throughout its length by staybolts. The upper edges of the sheets *s*<sub>1</sub> are flanged out to

an over-all width of about 13 inches and to a contour to correspond with the crown-sheet of the firebox, and are drilled to agree with the location of the radial stays.

**11. Application.**—The manner in which thermic syphons are applied to the crown-sheet is shown in Fig. 7. A space is cut out of the crown-sheet to correspond to the area of the top of the syphon, then its edges are set flush with the crown-sheet and welded. The radial stays are so arranged that a row comes

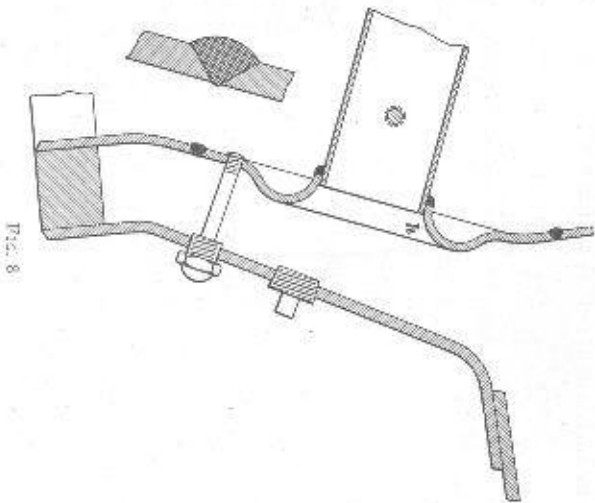

FIG. 8

between the welds and the syphon, thereby relieving them of stresses. It will be noted that the circular-shaped channels of the syphons serve to form a support for the brick arch.

At the front, the intake neck of the syphon is inserted into and welded to a flexible diaphragm plate *h*, Fig. 8. This diaphragm, or breathing plate, is  $\frac{1}{2}$  inch thick and is corrugated to permit the body of the syphon to come and go with the crown-sheet. The diaphragm plate is applied by cutting a hole in the flue sheet or in the inside throat sheet if a combustion chamber

is used to suit the plate, which is then welded in place and further supported by flexible stays. If desired, the diaphragm corrugations may be pressed directly into the flue sheet or throat sheet.

#### OIL-BURNING FIREBOX

**12.** A sectional view of a firebox for burning oil is shown in Fig. 9. The firebox differs from that of a coal-burning locomotive in that the grates and ash-pan are not used. The grates

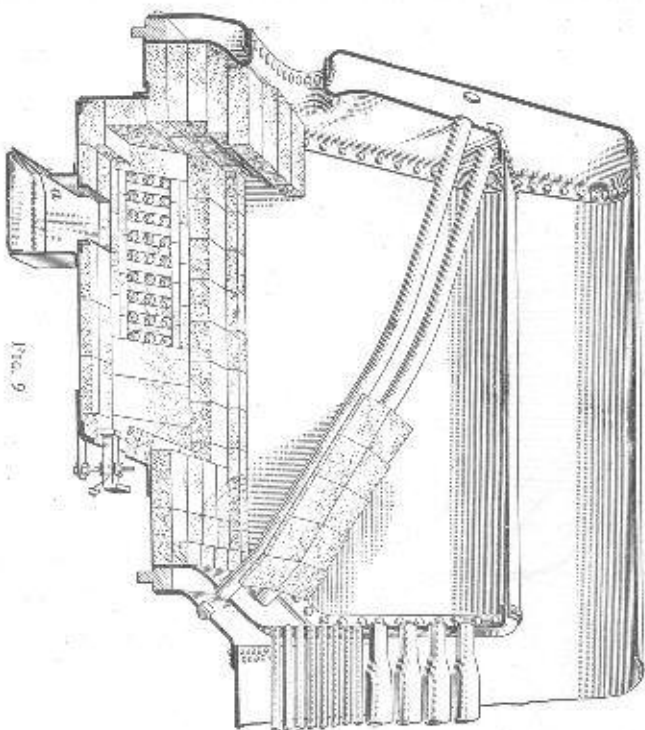

FIG. 9

are replaced by brick, and a hopper provided with a door *a* is used instead of an ash-pan. The sides of the firebox are lined with firebrick to a point above the direct path of the oil jet, so as to protect the sheets against the intense heat of the jet. The oil, which is vaporized in the burner *b*, is thrown against the flash wall at the back of the firebox. The air is supplied through the air holes *c* and also through the hopper door when it is opened and through a specially shaped firedoor.

## BELPAIRE FIREBOX

13. **Description.**—In Fig. 10 is shown a cross-sectional view of a Belpaire firebox. The difference between this and other types of fireboxes lies in the shape of the roof sheet and the crown-sheet, the Belpaire firebox being designed so that the crown-sheet *a* and the roof sheet *b* are comparatively flat and parallel with each other. With this arrangement the radial,

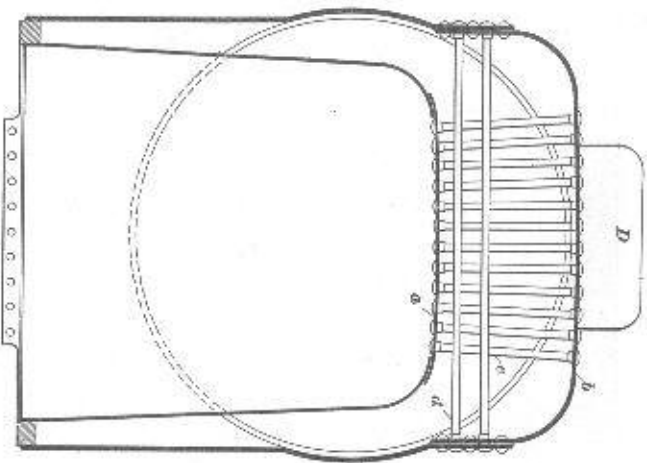

FIG. 10

crown, stays *c* are at right angles to both of the sheets, and this is a very desirable feature in staying flat surfaces under pressure. The upper section of the roof sheet is still further stayed by transverse rods *d*, which are placed at intervals in the steam space and are securely fastened at the ends. The Belpaire firebox gives an increased steam space owing to enlarging the upper part of the boiler but its principal advantage is the right-angle position of the crown stays with respect to the crown sheet.

The cylindrical part of the boiler in front of the firebox does not differ from any other type, and may be straight-top extended-wagon, or conical. However, the steam dome *D* is always placed on one of the courses in front of the firebox, because, on account of the flat surface, it cannot be very well placed over the firebox.

## WATER-TUBE FIREBOX

14. **Design for Withstanding Pressure.**—When it is required to confine liquids and gases under pressure, the ideal shape of the container is spherical. When it is impracticable to use a spherical container, the next in order of strength is one of cylindrical shape with convex ends. With the same thickness of material, a cylinder with convex ends will withstand a greater internal pressure than one with flat ends. A locomotive boiler has a cylindrical shell, but it is not possible to have the ends made convex. Strength is therefore obtained by having both ends, or the front tube-sheet and the back head, securely stayed to the shell, in which case the boiler nearly approaches the ideal for resisting pressure. The firebox, however, with its flat surfaces, is poorly designed to withstand pressure, and for this reason it requires careful staying.

The flat crown-sheet of the ordinary type of firebox cannot be safely stayed for pressures in excess of about 300 pounds, hence the boiler pressure is limited to the pressure for which the crown-sheet can be stayed with safety. When higher boiler pressures are desired, the water-tube firebox must be employed, but as high boiler pressures involve difficulties from scale as well as complications such as three cylinders in order to secure the proper expansion of the high-pressure steam, the water-tube firebox is in very limited use, and is here described merely to show the principle of construction.

15. The water-tube firebox is practically ideal from the standpoint of withstanding internal pressure, as all of the parts that contain water are cylindrical so that no staying is necessary. The principal objection to its use, unless the feedwater is pure, is the difficulty experienced and the time consumed in keeping

the water tubes clean and free from scale. With the ordinary form of locomotive boiler, scale is not a serious problem or is at least one that can be controlled because the storage space in which it can collect is large.

However, with a water-tube firebox the tubes are comparatively small and on this account can be easily partly obstructed or blocked by an accumulation of scale, thereby causing a flue failure. Water-tube boilers can be used in stationary practice because the steam after being used in the turbines is converted into water in the condensers. This water, which is practically free of scale-forming matter, is again sent to the boiler and evaporated and used over and over again so that there is only a limited amount of scale to be dealt with.

16. An exterior view of a water-tube firebox is shown in Fig. 11 (a). It comprises a drum *a*, 40 inches in diameter, that is in communication with the hollow back head *b*, and a water leg *c* formed by the throat sheet and back tube-sheet, a bottom side header *d* on each side, a top side header *e*, one on each side, and numerous tubes *f*, 2½ inches in diameter, on each side that make up the sides of the firebox. These tubes are expanded into the header at the top and into the foundation ring at the bottom. The back head and the door sheet are flanged and riveted together so as to form the customary water leg found on the ordinary boiler. The front and rear water legs are supported by staybolts, not shown.

A sectional view taken lengthwise is shown in view (b) and an end view is given in (c). In view (b) is shown a full view of the drum *a* broken away at the rear, the back water leg *b* and the front water leg *c* are shown in section, and the bottom side header *d* is broken away at the ends to show its method of connection to the water legs *b* and *c*. All of the tubes on the front side of the firebox are shown broken away, so the tubes shown in full are on the far side. As shown in view (c) the bottom side header is rectangular except at the ends, where it enters the water legs; here it is cylindrical in order to make a steam-tight connection. The header *e* is connected to the drum *a* by twelve short pipes *g*, ¾ inches in diameter. The tubes *f* are staggered and

in, connect  
rick arch.  
the back  
ected are  
ivets, not  
ack water  
front end  
the boiler  
rough the  
drum and  
views (a)

the tubes  
expanded  
through  
by plugs,  
the tubes,  
and is air-  
the firebox  
distance  
ing made  
brick wall  
ch.

the front  
ambustion  
< the hot  
lly trans-  
increasing  
ose tubes  
bes to all  
that are  
also act  
r of lap-  
are made

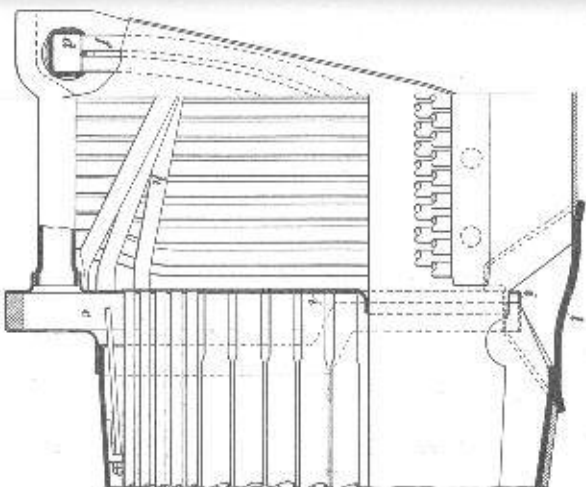

BR 501 (1927)

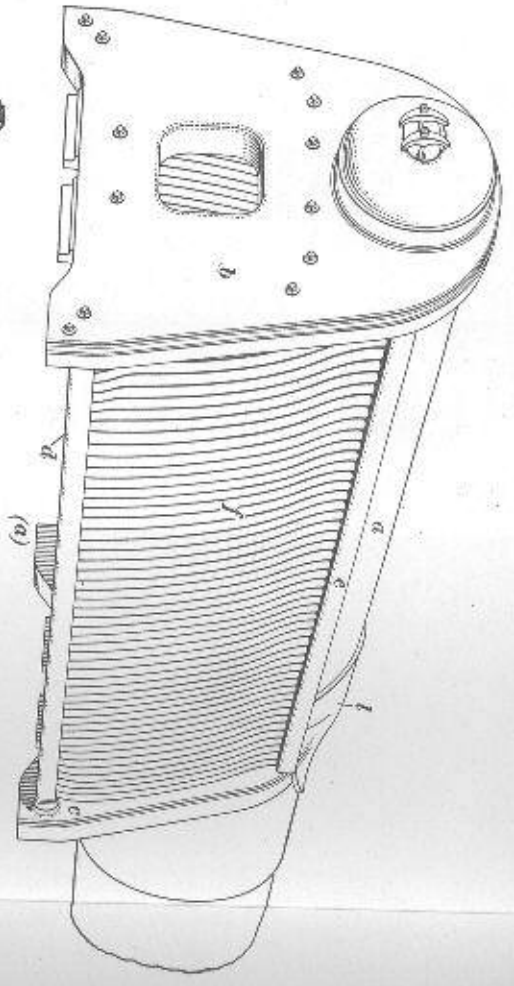
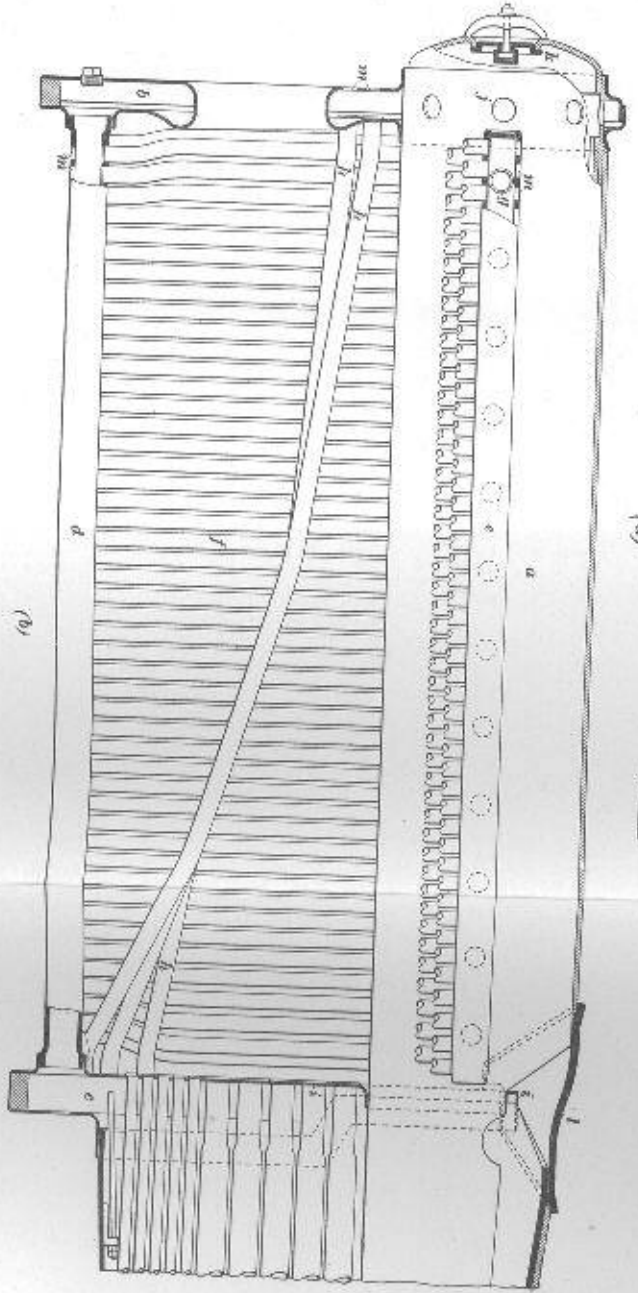
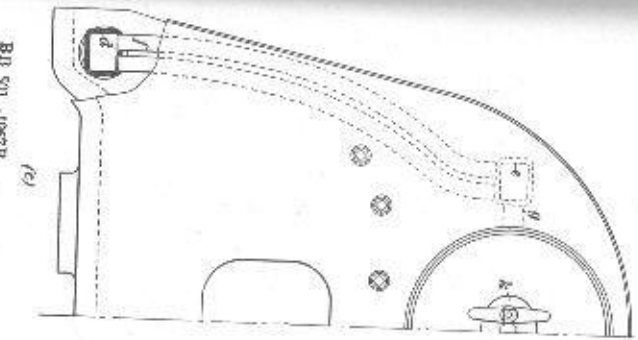

FIG. 11

the water form of 10 least one which it c

However tively sma or blocke failure. because it into water free of sc evaporate limited an

## 16. At

Fig. 11 (*d*) is in conn leg *c* form side heade and nume make up th the header The back together s ordinary b staybolts.

A sectic an end vie of the drr the front header *d* i nection to side of the full are or header is r legs; here tion. The pipes *g*, 3

arranged in two rows, and six arch tubes *h*, three shown, connect the two water legs and also serve as supports for the brick arch.

17. The drum *a*, Fig. 11 (*b*), extends through the back water leg *b* and the back tube-sheet *k*. The sheets affected are flanged and are riveted all around to the drum by rivets, not shown. The circulation between the drum and the back water leg occurs through eight holes *j*, equally spaced; the front end of the drum is not closed by a head but opens into the boiler proper. Access to the drum at the rear is made through the head *k*. The junction between the front end of the drum and the shell of the boiler is made by a heavy plate *l*, views (*a*) and (*b*).

The connecting pipes *g* and the arch tubes as well as the tubes that make up the sides of the firebox are rolled and expanded and in some instances beaded, all of which is done through holes *w*, at the end of every tube, normally closed by plugs. These plugs are removed when necessary to clean out the tubes.

The firebox is insulated to prevent the loss of heat and is airtight so that all air must enter through the grates. The firebox measures 11 feet in length and is 8 feet wide, but the distance between *b* and *e* is 16 feet, owing to an allowance being made for a combustion chamber 5 feet long formed by a firebrick wall across the firebox, and joined at the top to the brick arch.

## BOILER DETAILS

## TUBES AND FLUES

18. The tubes and flues connect the back and the front tube-sheets, and are used to convey the products of combustion from the firebox to the smokebox. They also break the hot gases into small columns so that the heat is more readily transmitted to the water which surrounds them, thereby increasing the heating surface. The term *flues* is applied to those tubes which contain the superheater units, and the term *tubes* to all the others. The tubes and flues are fitted into holes that are drilled in the front and the back tube-sheets, and they also act as stays for these sheets. Tubes and flues are either of lap-welded or of seamless construction. Lap-welded tubes are made

from strips of highly refined charcoal iron, or steel bent to shape and lap-welded at the joint. Seamless tubes are drawn from a block of refined iron or steel by special machinery which produces a tube without seams.

The tubes used in locomotive boilers are generally either 2 inches or 2½ inches outside diameter. Experience and experiments have proved that these sizes are the most desirable. If smaller sizes are used, the tendency is for the tubes to become

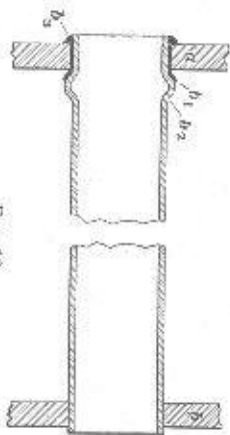

FIG. 12

stopped up, while increasing the size decreases the total tube heating surface and reduces the capacity of the boiler to generate steam. Small tubes have a greater heating surface in proportion to the volume of gases passing through them than do large ones, because the small tubes break the hot gases into smaller columns and thus utilize more of the heat, and the hot gases escape to the smokebox at a lower temperature.

**19. Application of Tubes.**—The tube holes in the tube-sheets are drilled to size before the sheets are put in place. The tubes are always applied and removed through the front tube-sheet and, to facilitate the application and the removal of the tubes, the tube holes in the front tube-sheet are drilled  $\frac{1}{16}$  inch larger in diameter than the holes in the rear tube-sheet to permit the tubes to be slipped through freely. In some cases a single hole in the front tube-sheet is made  $\frac{1}{4}$  inch larger in diameter than the others, and all of the tubes are applied and removed through this one hole when making a complete installation of new tubes. This method has the disadvantage of making it difficult to remove a single tube, as the heavy coating of scale that always accumulates on a tube makes it hard to drive the tube out, but

the method has the advantage of doing away with the necessity of expanding the tubes so much at the front tube-sheet.

The holes in the back tube-sheet *a*, Fig. 12, are slightly larger than the tubes so as to permit a copper ferrule *b*<sub>1</sub> to be inserted in the hole between the sheet and the tube.

The ferrule is a piece of copper pipe  $\frac{1}{8}$  inch in thickness and  $\frac{3}{8}$  inch long and is rolled lightly in the hole before the tube is inserted. The tube extends about  $\frac{7}{8}$  to 1 inch beyond the face of the sheet into the firebox and is rolled tight against the ferrule and the sheet by means of roller expanders. The tube is then expanded by sectional expanders to bell it out on the inside as shown at *b*<sub>2</sub>. The end which extends beyond the sheet is then turned over and beaded down firmly, as shown at *b*<sub>3</sub>, by use of a beading tool of special form. Finally, the tube is electrically welded all the way around as a positive means of preventing leaks.

**20.** By this method, the tube, in addition to being securely rolled in place, is clinched and welded against the sheet on both sides, and therefore makes a strong joint. The ferrule *b*<sub>1</sub> is placed flush with the face of the sheet on the fire side and serves to make a tight joint between the tube and the sheet, because when the tube is expanded the ferrule, being soft, will fill completely any opening between the tube and the tube hole. The ferrule also prevents the tube from leaking,

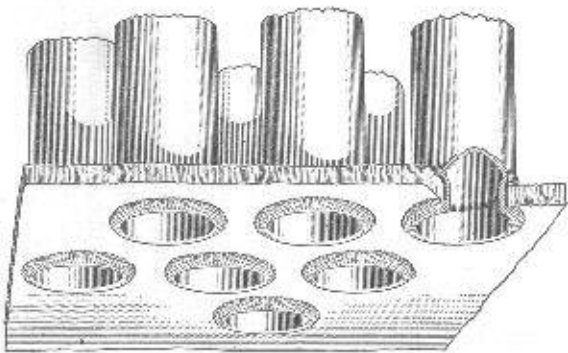

FIG. 13

prevents it from leaking, because it keeps the space between the expanding and contracting surfaces of the tube-sheet and the tube always filled.

The section of the tube-sheet in Fig. 13 shows how the tubes appear when they are beaded over and welded.

The tubes are rolled at the front tube-sheet *b*, Fig. 14, in the same manner as at the back tube-sheet, but the sectional expander is not used, and the tubes, according to local conditions and practice, may or may not be beaded as shown at *b*<sub>1</sub> on the other end, but some are always beaded for staying purposes.

**21. Superheater Flues.**—The superheater flues necessarily have to be of a larger diameter than the tubes to make provision for the superheater units.

To permit the installation of the units and still have sufficient space for the hot gases to pass through and circulate around the units, the tubes, or flues, as they are generally called, are made  $5\frac{1}{8}$  or  $5\frac{1}{2}$  inches outside diameter with the firebox end swaged down to  $4\frac{3}{8}$  to  $4\frac{1}{2}$  inches, as shown in Fig. 14. The effective area through which the gases can pass when the superheater

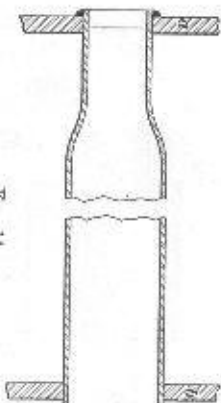

FIG. 14

units are in place is of course greatly reduced so that there is no reason why the firebox end of a tube cannot be made smaller and still be of sufficient size to provide space for the flow of the gases.

The flues, Fig. 14, are beaded at the firebox end so that they may be more securely held in position. In some cases, ferrules are used, the same as with the small tubes, while in other cases they are omitted; in this event the flue is welded to the sheet, as shown. At the front end, the superheater flues are merely expanded.

When removing a tube or flue, the beading and welding at the back tube-sheet is chipped off and the front end of the tube is burned off just back of the ring made by the expander. The piece that now remains in the front tube-sheet is chipped out and the tube or flue is driven forwards and outwards.

#### THE STEAM DOME

**22. Description.**—The steam dome is a cylindrical receptacle on the top of the boiler, and is used for collecting and holding dry steam. It is usually placed on the boiler course in

front of the firebox, although with the smaller and older types of boilers the steam dome was placed directly over the crown-sheet. As is shown in the sectional view, Fig. 15, the steam dome is made up of a cylindrical barrel *a*, which has a double-riveted butt joint on one side, not shown, a heavy flanged collar *b* to which the barrel is riveted, and a cast-steel ring *c* to which the cover, not shown, is secured by bolts. The dome may also be made in one piece, as shown in Fig. 16, by pressing it to shape in a flanging press. This method eliminates the riveting in the butt joint and also in the collar and ring. The dome, whether

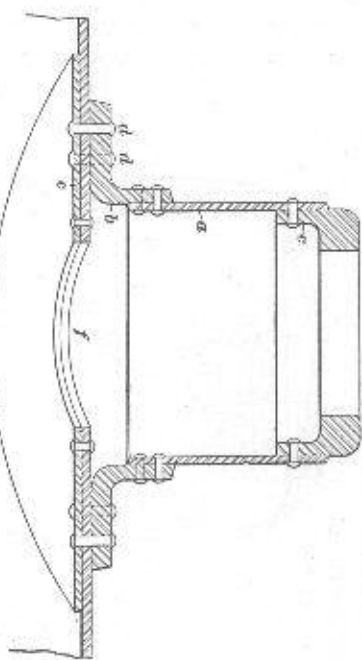

FIG. 15

built up or in one piece, is riveted to the boiler shell by a double row of rivets *d* which extend through the dome base, the boiler shell, and the dome liner *e*. The liner is necessary to strengthen the boiler shell, which is weakened by the cutting of the large hole *f* in the plate. This hole permits dry steam to enter the dome and also provides an opening for the throttle pipe *f*, which connects to the dry pipe *f*<sub>2</sub>. The throttle valve *f*<sub>1</sub> controls the passage of steam from the dome to the throttle pipe and dry pipe.

**23.** The hole *f* also provides an opening through which a man may enter the boiler to inspect the interior or to make necessary repairs, and it is the only opening in the boiler that is large enough for this purpose. The opening *f* should not be

made larger than is absolutely necessary, because its size seriously affects the strength of the shell; the larger the opening the weaker the shell, other things being equal. The opening is about 33 inches in diameter.

The dome cover, which closes the opening on the top of the dome, should be kept reasonably small, as the only method of staying is by bolting it to the outer edge of the ring or to the inner edge of the dome, if a one-piece dome is used.

Domes are made about 2 feet 6 inches in diameter and from 12 to 36 inches high. The size of the dome depends on the size of the boiler and the clearance of the right of way, the latter

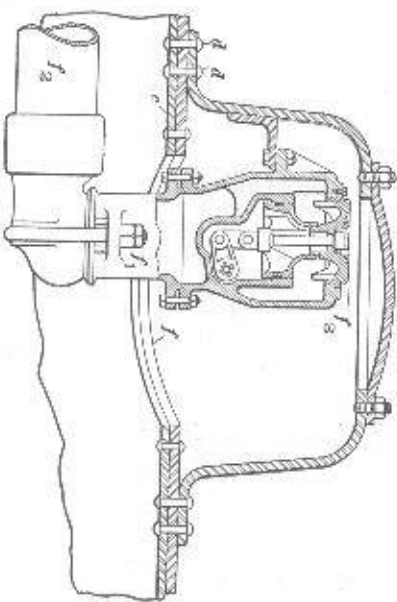

Fig. 16

preventing the use of a high dome on large boilers. The dome, being the highest point above the surface of the water, is an ideal place in which to put the throttle valve; for to reach it there the steam must travel farther before it enters the valve and this insures dryer steam because the steam is more thoroughly relieved of any water that may be entrained in it.

In boilers of very large capacity, an extra dome, called an auxiliary dome, is sometimes used to which the safety valves and the whistle are attached. In such case the dome that contains the throttle valve can be located nearer the front end. This arrangement is an advantage with long boilers because the length of the dry pipe is reduced.

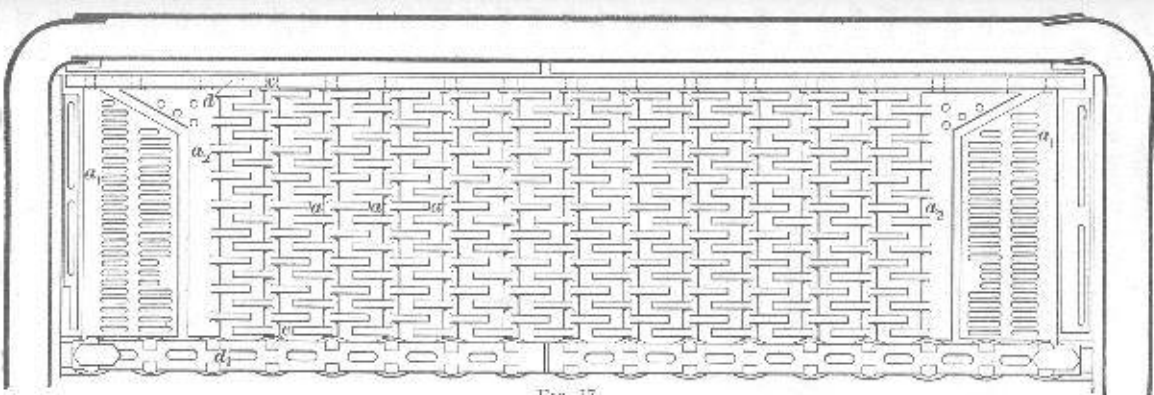

Fig. 17

## GRATES

24. Description. — The grates usually consist of a set of parallel bars called grate bars, made of cast iron, and placed at the bottom of the firebox. The purpose of the grates is to hold the fuel as it is being burned.

Grates are classified as rocking, or shaking, grates; dead, or dump, grates; and corner grates. In Fig. 17, which shows one-half of a section of grates, the rocking grates are marked *a*, the dump grates *a*<sub>1</sub>, and the corner grates *a*<sub>2</sub>. The shaking grates have trunnions *c* on the ends of the grate bars which are carried by the grate bearers *d* and *d*<sub>1</sub>.

Rocking or shaking grates, which are shown in section in Fig. 18, consist of a series of flat, or finger, grate bars. These grate bars can be turned out of a horizontal position by connecting rods *b* that are pinned to the projections *f* on the lower side of the grate bars. The rods *b* are connected by rods *b*<sub>1</sub> to levers *d*<sub>1</sub> which extend through to the cab deck and are attached to

27. The Inulson tuyère type of grate, which is designed to restrict the air openings to any amount desired, is shown in Fig. 19. This grate takes its name from the fact that the air is admitted through tuyères *a*, view (a), in the castings *b* that are assembled one at a time from the end of the grate bar *c*. These castings, view (b), are identical and when placed with the inside faces together, view (c), passageways *d* are formed between them, open at the bottom and covered at the top. From these passageways the air enters valleys *e* formed between each

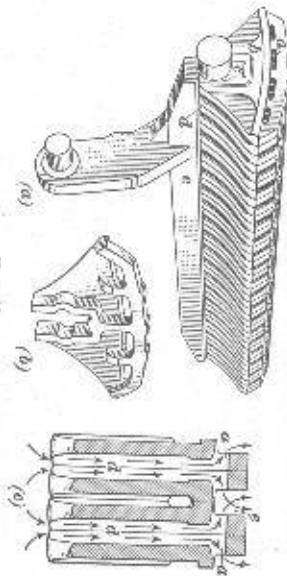

FIG. 19

pair of fingers by the spacing ribs shown. The incoming streams of air baffle each other in the valleys, thereby reducing their velocity but not their volume. The total air opening is governed by the number and the size of the tuyères and not by the area of the valleys, and this opening may vary from 37 per cent. of the total grate area or less, as may be desired.

## ASH-PAN

28. The ash-pan is a receptacle placed under the firebox for the purpose of collecting and holding the ashes which drop or are dumped through the grates. Ash-pans should be constructed so as to prevent, as far as possible, live coals from dropping through and starting fires along the right of way.

In Fig. 20 is shown an exterior view of the side of an ash-pan used with a wide firebox. The principal parts of an ash-pan are the receptacle proper, an arrangement for dumping the ashes, and in some cases dampers to control the admission of air to the fire. Ash-pans are made in a large number of different styles

and shapes, depending on the size of the firebox, the wheel arrangement of the locomotive, and the service in which the locomotive is used.

The size of the firebox materially affects the type of ash-pan used, as the pan must extend under the entire grate surface.

The ash-pan shown in Fig. 20 is made up of two hoppers *a*, hence the term *hopper ash-pan*. The hopper arrangement is necessary because the trailing wheels come in about the center of the pan. The bottoms of the hoppers are closed by cast-iron doors *b*, which may be operated by a series of levers from the cab or by a compressed-air apparatus. The hoppers have a width of 24 to 30 inches at the bottom and gradually extend

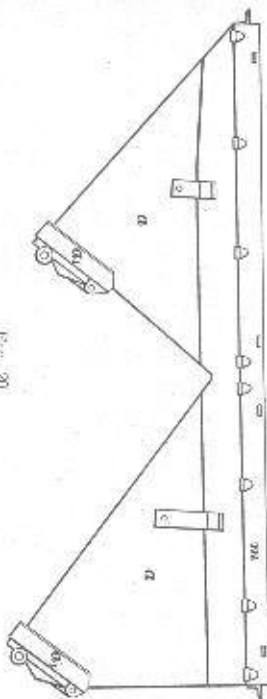

FIG. 20

upwards and outwards to the foundation ring *m*. The sides of the pan extend up over the frames to a point level with or slightly above the bottom of the ring. In some cases the pan is attached directly to the ring, and in others a space of from 3 to 5 inches is left between the pan and the ring so as to provide a space through which air can enter to the under side of the grates. When the sides of the pan are bolted directly to the ring, pockets or perforated plates are inserted along the sides and also at the ends of the pan to provide the necessary air inlets. The preferred way is to have the air inlets at the top of the pan away from the ashes.

When very wide fireboxes are used, the ash-pan may have a series of hoppers between the frames and also on the outside of the frames on each side, but the principle of construction is the same as already described.

On account of the numerous classes of locomotives, there is no one style of ash-pan that can be considered as a standard. Nearly all the large railroad companies have adopted styles to suit their own special purpose.

By orders of the Interstate Commerce Commission, all ash-pans must be equipped with some device whereby they can be cleaned or dumped without the necessity of going under the engine to do it. The means provided for this purpose are operated from the cab either by hand, air, or steam, at the convenience of the engineer. The hoppers and the hopper doors are made of cast steel or malleable iron. The plates used in the construction of the rest of the pan are usually  $\frac{1}{2}$  inch, or  $\frac{3}{8}$  inch thick. Some pans are made of one piece of cast steel but this practice is not general.

**29. Air Inlets in Ash-Pans.**—Although the ash-pan is intended primarily as a receptacle for ashes, yet it is one of the most important adjuncts affecting combustion that is placed on the locomotive. The function of the appliances in the front end is to maintain a partial vacuum in the firebox, and the amount of vacuum necessary in the firebox to burn the fuel at a certain rate depends on the difference in pressure above and below the grates. Under ordinary conditions the pressure in the firebox is only about 2 ounces less than that of the surrounding air. If, therefore, the ash-pan is so designed that sufficient air cannot flow under the grates to maintain atmospheric pressure, it follows that to obtain the necessary difference in pressure a higher vacuum must be created in the firebox. This can be obtained only by reducing the size of the nozzle, which in turn results in higher back pressure and affects adversely locomotive operation.

It has been generally admitted that openings in the ash-pan equivalent to about 15 per cent. of the total grate area are sufficient under practically all conditions to maintain atmospheric pressure under the grates. Tests have demonstrated, however, that even with this ratio of air opening, a partial vacuum equal to .6 inches of water frequently occurs under the grates under certain conditions of operation, and this partial vacuum is equivalent

to reducing the vacuum above the grates by an equal amount. Therefore, the practice is to employ air openings somewhat in excess of 15 per cent. of the total grate area.

#### CIRCULATION IN BOILERS

**30. Importance of Circulation.**—Circulation in locomotive boilers is the name given to the motion of the water under the influence of heat. The water nearest to the source of heat is heated and expands, and thereby becomes lighter and rises to the top. As this water rises to the surface, other cooler water will take its place, become heated, and also rise. The circulation of the water keeps the heating surfaces covered with water at all times and thus prevents any part from becoming overheated or burnt. Circulation secures regularity and steadiness in the generation of steam, tends to equalize the temperature throughout the boiler, and prevents unequal expansion and consequent straining of the different parts. The circulation of the water tends to maintain the greatest possible difference of temperature between the water on one side of the plates and the hot gases on the other side, thus enabling the heat to be absorbed readily. In addition, circulation tends to keep the heating surfaces as clear of mud and other deposits as possible. The more rapid the circulation, the greater the amount of heat that will be transferred from the firebox and tubes to the water.

**31. Advantages of Proper Circulation.**—The advantages derived from proper circulation may be summed up as follows: The boiler is kept cleaner, so more water will be evaporated per pound of fuel, which results in a saving of coal. There are fewer strains on the boiler due to unequal expansion and contraction, and there is less corrosion and pitting of the sheets.

The circulation of water in a locomotive boiler is shown in Fig. 2. The heated water from around the firebox rises to the surface and takes steam bubbles with it. The cooler water from the front of the boiler, where nearly all feed-water inlets are located, flows back to take the place of that which has moved upwards. In this way a circulation of water is maintained in the general direction indicated by the arrows.

In locomotive boilers, the large number of tubes and flues makes it important that they be so spaced as to interfere as little as possible with the circulation of the water around them. There are two methods of arranging the tube spacing in boilers. In Fig.

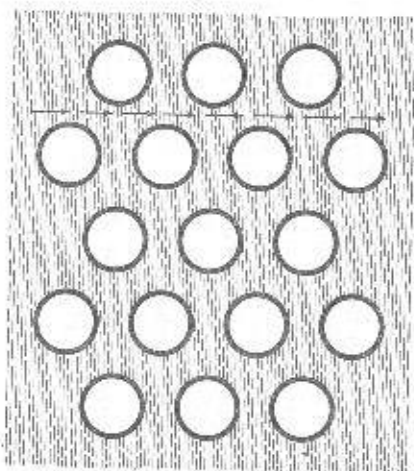
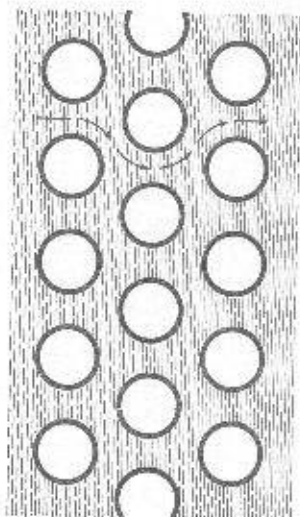

FIG. 21

21 (a) is shown what is called zig-zag spacing, and view (b) shows vertical spacing. The second method is more generally used because, as shown by the arrows, there is less obstruction to the steam bubbles as they rise to the surface than with the arrangement shown in view (a).

#### HEATING SURFACE

32. **Definition.**—The heating surface of a locomotive boiler is that part of the boiler that is exposed to the direct heat of the fire or the gases of combustion on one side, and which has water available for evaporation on the other side.

33. **Kinds of Heating Surfaces.**—Heating surface is usually divided into firebox heating surface and tube and flue heating surface. The firebox heating surface consists of the sheets of the firebox above the grate level, and comprises the crown-sheet, the side sheets, the door sheet less the area of the door hole, and the back tube-sheet less the internal area of the tubes and flues. Tube or flue heating surface comprises the total outside surface of the tubes and flues between the front and the back tube-sheets. The area of the front tube-sheet is not taken into consideration in calculating the heating surface. Heating surface is usually expressed in square feet.

34. **Efficiency of Heating Surface.**—The efficiency of the heating surface depends on the following factors: The location and condition of the heating surfaces, and the arrangements by which the water has rapid and free circulation throughout the boiler. The location of the heating surface has an important influence; for the surface in direct contact with the fire will evaporate water at a much higher rate than an equal amount of heating surface that is not in direct contact with the fire, such as the tube heating surface.

If the tubes and flues become coated with scale on the water side or are partly or entirely plugged with soot on the fire side, these surfaces will conduct less heat to the water, and the efficiency of the surface is lowered because it does not evaporate the amount of water that it should.

The location of the entry of the feed-water may be such as to hinder proper circulation. The tubes and flues may be placed too closely together, in which case the water may be retarded from coming into contact with the proper heating surfaces; thus the rate of evaporation and hence the efficiency of the surface will be lowered.

Of the different heating surfaces of the boiler, the crown-sheet surface is the most effective, then that of the side, tube, and door sheets in the order named, and the tube and flue surfaces last. In calculating the evaporation values, all the sheets of the firebox are taken at the same rate, likewise the rate for the tubes and flues is taken as the same.

**35. Direct and Indirect Heating Surfaces.**—The heating surface of the firebox sheets and arch tubes is termed the direct heating surface, as these parts are subject to the direct action of the fire. The surfaces of the tubes and flues are called the indirect heating surfaces because these surfaces are only exposed to the heat of the gases that have passed out of the firebox. The sum of the direct and indirect heating surfaces is the total heating surface of the boiler.

#### BOILER EVAPORATION

**36. Calculating Evaporation.**—Boiler evaporation refers to the total amount of water evaporated into steam by the heat generated in the firebox and the tubes and flues.

The total evaporation with a modern locomotive boiler is very difficult to determine with accuracy for any given condition. The rate of heat transfer by radiation of firebox heating surface, upon which the greater amount of the evaporation depends, involves so many factors that it forms a very complicated problem. The rate of heat transfer varies with the grate area, the firebox heating surface, the rate of firing, the ratio of firebox heating surface to combustion volume, the distance from the source of heat to the heating surface, the temperature of combustion, the amount of air used per pound of fuel in the process of combustion, as well as other factors.

**37.** The generally accepted figure was an evaporation of 55 pounds of water per square foot of firebox heating surface per hour on a basis of 12,000 B. t. u.'s per pound of coal, but this was with a firebox without a combustion chamber or syphons. With modern fireboxes, on account of their greater heating surface, the total maximum evaporation will be greater, but the unit rate of evaporation per square foot of heating surface will doubt-

less be less because of the lower average temperature in the firebox. The evaporating rate for the tubes and flues of earlier types of boilers was taken as about 10 pounds of water for each square foot of outside heating surface per hour for a 24-inch tube 18 feet long, but this figure will not apply to modern boilers.

The total evaporation of the combined heating surfaces of the firebox and the tubes and flues can be found from road tests in which a check is made of the weight of water supplied to the boiler per hour. Such a test would show an evaporation of about 7 or 8 pounds of water per hour for each square foot of heating surface of the firebox, tubes, and flues.

#### 38. Steam Required per Cylinder Horsepower Hour.

Tests have shown that the development of one cylinder horsepower for one hour, which is the equivalent of raising 1,980,000 pounds one foot in one hour, requires 20.8 pounds of steam for a locomotive using steam of a moderate degree of superheat, as obtained with a type A superheater. With steam pressures of from 225 to 275 pounds and 300 degrees of superheat, as with a type E superheater, and with feedwater heaters and large grates, one cylinder horsepower for one hour can be developed from 17½ pounds of steam.

Therefore, the steam required per hour is equal to the horsepower of the locomotive multiplied by either 20.8 or 17.5.

**EXAMPLE.**—How much steam is required per hour for a steam locomotive of 2,000 horsepower equipped with a type A superheater?

**SOLUTION.**—Each horsepower developed requires 20.8 lb. of steam, hence the total amount of steam for 1 hour is  $2,000 \times 20.8 = 41,600$  lb. Ans.

As it requires one pound of water to generate one pound of steam, the weight of the water used will be 41,600 pounds, or almost 5,000 gallons per hour.

#### 39. Coal Required per Cylinder Horsepower Hour.

The quantity of coal required for the development of one cylinder horsepower for one hour will average about 3.25 pounds for locomotives with moderate boiler pressures, equipped with type A superheaters. With high pressures and high superheat, a fair average would be 2.5 pounds.

**40. Boiler Horsepower.**—The boiler horsepower can be found from the following rule:

**Rule.**—To find the boiler horsepower, divide the total evaporation per hour by the pounds of steam required per cylinder horsepower hour. This is 20.8 pounds for moderate superheat and 17.5 pounds for high pressure and high superheat.

**EXAMPLE.**—The total steam evaporated with a locomotive equipped with a type A superheater is 39,600 pounds per hour. What is the boiler horsepower?

**SOLUTION.**—The boiler horsepower is equal to  $\frac{39,600}{20.8}=1904$ . Ans.

As already pointed out, the application of the foregoing rule is complicated by the difficulty in calculating the total evaporation with modern locomotive boilers.

It is desirable to proportion the heating surface so as to make the boiler horsepower equal to at least the cylinder horsepower. It has been shown that a boiler horsepower in excess of the cylinder horsepower results in considerable economy in fuel and water.

#### CALCULATING THE GRATE AREA

**41. Rate of Combustion.**—The rate of combustion is stated in terms of number of pounds of coal burned per square foot of grate area per hour. If the grate area is 60 square feet, and if 3 tons of coal is burned in 1 hour, the rate of combustion is 100 pounds of coal per square foot of grate area per hour.

**42. Grate Area Required.**—For high-grade bituminous coal, containing about 14,000 British thermal units per pound, the maximum rate of combustion for economical evaporation has been found to be about 100 pounds per square foot of grate area per hour. Larger amounts than this have been burned, but careful tests show that such practice is wasteful of fuel and results in low evaporation per pound of coal.

When the horsepower to be developed is known, the amount of coal that must be burned to produce it can be determined as explained in Art. 39, where it was stated that horsepower  $\times 3.25$  or  $\times 2.5$  = pounds of coal required per hour.

The grate area required to burn the amount of coal required can then be found by dividing the total coal that must be economically burned per hour by the number of pounds that can be burned per square foot of grate area per hour. The rule, then, for finding the grate area is as follows:

**Rule.**—To obtain the grate area, in square feet, for burning bituminous coal, divide the total coal to be burned, in pounds per hour, by 100.

**EXAMPLE.**—Find the grate area required for a locomotive of 2,542 horsepower burning bituminous coal.

**SOLUTION.**—The coal required to be burned per hour is  $2,542 \times 3.25 = 8,261.50$  lb. The grate area is therefore  $\frac{8,261.50}{100} = 82.6$  sq. ft. Ans.

#### LOCOMOTIVE BOILER DESIGN

**43. Principles of Design.**—The design of the locomotive boiler and firebox and their appurtenances should be such as will permit of the greatest possible evaporation from a given amount of fuel. It is an advantage if the boiler capacity is equal to or in excess of the cylinder requirements. When this is the case, the maximum hauling capacity of the locomotive can be obtained even when working under somewhat adverse conditions.

In modern locomotive practice, all things are made subordinate to the boiler and the cylinders. Of these two, the boiler is first in importance, as the performance of the locomotive depends on the ability of the boiler to generate steam. If the boiler fails to supply the required amount of steam, the result will be a locomotive that will not haul the train without losing time, except with a reduced tonnage.

Again, a boiler may provide sufficient steam, but the grate area may be incorrectly designed and proportioned. In this event the locomotive will be wasteful of fuel.

In order that modern locomotives shall do the work required of them, it is necessary for the boiler to be properly constructed, for the firebox to be of sufficient size to produce the best possible combustion of the fuel, and for the grate area to be such that the fuel will be burned economically.

Reliable tests have shown that a square foot of firebox heating surface will evaporate about five times as much water per hour as a square foot of tube heating surface. It is therefore an advantage to have a relatively large firebox heating surface.

The demand for heavy power has necessitated increasing the size of the boiler to such an extent that locomotive boiler design is a problem that requires careful study.

Of all steam-generating devices, the locomotive boiler is undoubtedly the most severely taxed as a structure. The reasons are as follows: The boiler cannot be perfectly insulated from cold; it must stand the effects of severe strains due to rapid and uneven heating up and cooling off while in service; it is subjected more or less to sudden cooling at the ash-pit and on the way from the ash-pit to the engine house; and, when required for service, steam is very often raised quickly, thereby causing very rapid expansion and the setting up of stresses that ultimately will cause rupture of some part.

#### CONSTRUCTION OF BOILERS

**44. Principles of Construction.**—Two of the fundamental principles in boiler construction are, the boiler must be constructed so that it will withstand a pressure considerably in excess of the working pressure, and the construction should be such as to prevent disastrous results if the boiler should explode through neglect or carelessness.

The art of boiler making has been developed to such an extent that it is possible to build boilers that will withstand the high pressures now required with less danger of explosion than existed with the lower pressures that were used with the older types.

**45. Order of Construction.**—The construction of a locomotive boiler may be divided into a series of operations which briefly are as follows: (1) Procuring and testing materials; (2) laying out or marking off the sheets or plates; (3) punching the plates; (4) rolling or bending the plates to shape and flanging the plates that require it; (5) machining the plates, such as drilling the tube and flue holes, etc.; (6) assembling the several

pieces; (7) riveting; (8) applying staybolts and stays; (9) calking all joints; (10) testing.

**46. Materials.**—The materials used in the construction of locomotive boilers are wrought iron, mild steel, and cast steel. Mild steel and alloy steel are used almost exclusively for the shell, heads, and firebox sheets. Tubes and flues are made from mild steel or highly refined iron, and staybolts and stays from refined iron or mild steel. The foundation ring is made of cast steel or wrought iron.

The steel used in boiler construction must be of the best quality obtainable, and should be designated and marked either as *flange steel* or *firebox steel*. Plate stamped by the manufacturer with either of these designations and also with the tensile strength of the piece is usually accepted as being made in accordance with the requirements of Federal and state laws governing the manufacture of plate. The plates should have a tensile strength, that is, a resistance to the pulling apart of the particles, of not less than 55,000 pounds per square inch, and not more than 65,000 pounds per square inch.

Wrought iron, mild steel, cast steel, and refined iron used for the details of the boiler should be in accordance with standard practice and the laws governing it. All iron and steel should be free from seams and mechanical defects and should show a uniformly fibrous structure throughout.

**47. Laying Out Plates.**—The first step in the construction of a boiler after the plates are received is to lay out or mark off the different parts that go to make up the boiler. These parts consist of one or more cylindrical courses; the taper, or conical, course if there is one; the front and back tube-sheets; the door sheet; the throat sheet; the side and crown sheets; the roof sheet; the back head, and the smokebox. Great care must be taken in the laying-out of the plates so that all rivet holes and staybolt holes are in proper alignment.

**48. Punching, Flanging, and Rolling.**—The sheets after they are laid out are taken to the punching machine where all holes for rivets, staybolts, etc., are punched. The plates are

then trimmed to the required size and shape either by shearing, or burning off the surplus material with the oxyacetylene torch. The sheets that require flanging are then taken to the flange shop where they are flanged by a flanging press. The sheets are heated, and then the flanging press by the use of specially formed dies, forms the flange by hydraulic pressure in one or two operations depending on the shape of the sheet. The sheets that require flanging are the front and the back tube-sheets, door sheet, throat sheet, and back head. After the front and the back tube-sheets are flanged, they are taken to the drilling machine where the tube and flue holes are drilled in them.

The cylindrical courses and the taper and conical courses, after being punched and trimmed to size and shape, are taken to the rolls, where they are rolled to a circular shape. It is very important that these sheets be rolled to a perfect circle, as otherwise the action of the pressure when the boiler is under steam will tend to force the sheet into a circle. This action is liable to start the seams and joints and may result in a leaky boiler.

This is especially true of the construction of the longitudinal butt joints, where, unless care is exercised, a flattened surface will result by reason of the several thicknesses of plate being placed together. The inside firebox sheet and the roof sheet are finally rolled to conform to the shape of the firebox.

**49. Assembling.**—As all the sheets are now shaped, they are set up or holed in their respective places. The barrel, or shell, is usually put together first. After being securely holed together, all holes are reamed out to the required size of the rivets. The barrel is then taken out to the riveting machine, where by hydraulic pressure the various sheets are riveted together under a pressure of from 75 to 150 tons. The firebox sheets are then assembled and riveted together in much the same manner, and the firebox is then placed in the shell in its proper place in relation to the rest of the boiler. At this time, the holes for the staybolts that support the flat surfaces of the firebox are tapped out and the staybolts inserted and riveted over at the outer ends, if stays of the type requiring riveting are used. The stayrods that support the back head and the front tube-sheet are also fitted

and riveted to the outer shell. The various sheets being now assembled and all rivets and staybolts in place, the seams or joints are made steam-tight, or *caulked*, as it is called, by means of a caulking tool held in a pneumatic hammer. The tubes and flues are inserted in place, and rolled, expanded, and beaded or welded. On the completion of this, the boiler is ready to be tested.

#### CARE OF BOILERS

**50. Low Water.**—The efficiency of a locomotive boiler depends largely on the care it receives. It is of first importance that those in charge see that there is at all times a sufficient quantity of water in the boiler to cover the crown-sheet and thereby make it impossible for the sheet to become overheated. The firebox sheets and the tubes are in contact with the fire, and they would become heated to the temperature of the fire if it were not for the water on the other side. The temperature of the water depends on the boiler pressure, and rarely exceeds 400° F. Therefore, while the sheets are in contact with the water they cannot greatly exceed this temperature, although the temperature in the firebox may exceed 2,500° F., which is about the fusing point of firebox steel. The heat in the firebox is conducted through the plate to the water and is absorbed, thereby preventing the sheet from heating to the temperature of the fire.

If, however, the transmission of the heat to the water is obstructed by scale or grease, or if the water, owing to being light and foamy, fails to absorb the heat, the plates will retain the heat and may become red-hot; or if, from any cause, the sheets are unprotected by water, they may become overheated. Metal loses its strength when heated, and, if heated to a high temperature, has comparatively little strength to resist the pressure within the boiler; as a result, the sheets are forced off the stays and failure occurs. It is a well-recognized fact that scale or grease may be the direct cause of an explosion.

The crown-sheet is the highest sheet in the firebox and it will be the first to become dry in the event of low water. An overheated crown-sheet invariably results in an engine failure or a boiler explosion. An important factor in the prevention of low water is the proper maintenance of the water registering devices.

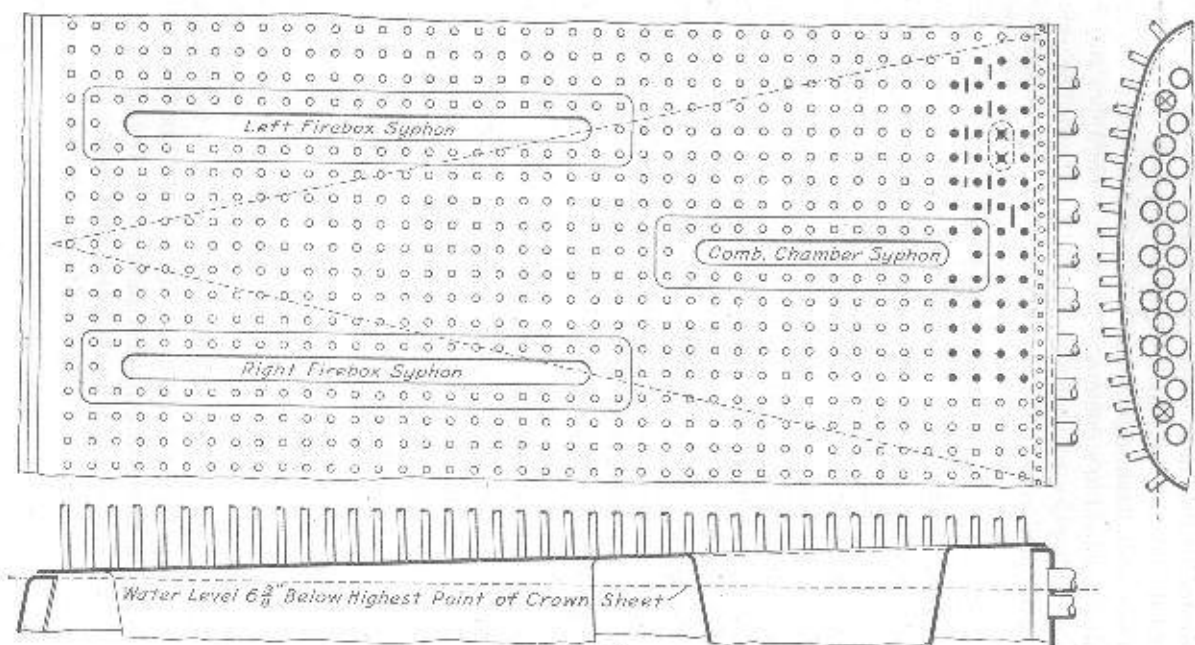

FIG. 22

51. **Examples of Overheated Crown-Sheets.**—In Figs. 22 and 23 are shown examples of crown-sheets damaged by low water, but not to such an extent as to cause a boiler explosion. In Fig. 22, the portion of the crown-sheet that was overheated is indicated by the staybolts shown in black. The two staybolts within the dotted enclosure and indicated by wings, pulled through the sheet and the sheet itself was bagged  $\frac{3}{8}$  inch. All the other staybolts in black were loose, and at the points indicated by heavy marks the sheet was bagged from  $\frac{1}{16}$  to  $\frac{3}{8}$  inch. The area of the crown-sheet within the large dotted triangle would have been burned were it not for the flow of water induced by the syphons, thus probably preventing a disastrous boiler explosion.

In Fig. 23 the area within the dotted line *abc* was overheated. The four staybolts within the area *d* were pulled out and this area, which was about 10 inches square, was bagged to a depth of 14 inches. The two rows of staybolts within the individual circles were loose, while those with the wings were partly pulled out. The narrow area of the sheet between the two rows of loose staybolts was bagged from  $\frac{1}{8}$  to  $\frac{3}{8}$  inch. The entire area within the dotted lines *ef* would have been damaged were it not for the syphons.

52. **Loose Crown Stays.**—The most striking feature of an overheated crown-sheet is the number of crown stays that are loose; in fact, the first indication of a leaky crown-sheet is leaky crown stays. The reason is that, in the application of the crown stays, the stays are screwed in tightly, thus putting the metal adjacent to the holes under a strain, and causing the metal to grip the stay and keep it tight. That is, the particles of metal immediately around a crown stay will be crowded closer together than those farther out.

Now, it is a well-known fact that heating a metal to the proper temperature, as is done when annealing main rods, side rods, etc., relieves it of any internal strains because of the physical change that takes place in the metal owing to the heat. As soon as the absence of water causes the crown-sheet to begin to heat up, an annealing action immediately starts in the metal, and its

elasticity around the crown stay is removed or the grip of the sheet on the stay relaxes, so that the particles of the metal that heretofore were crowded closely around a stay will begin to move away from it toward an area where they are not in such close contact.

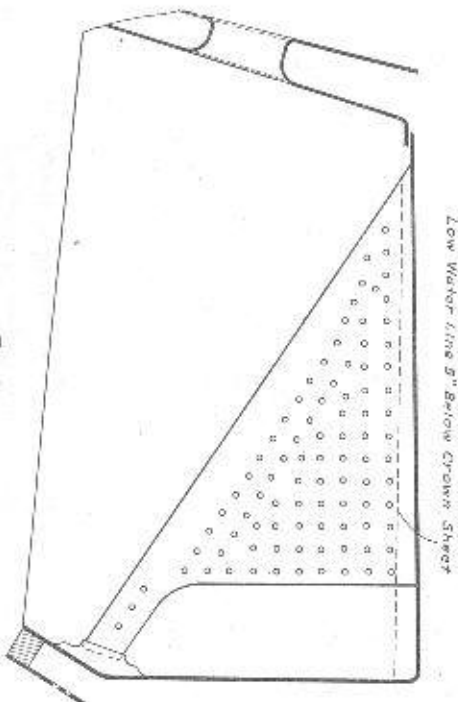
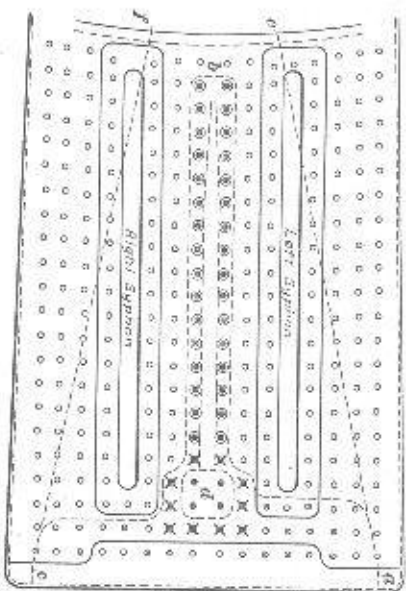

FIG. 23

As soon as this action, which is actually a slight shrinkage of the sheet around the stay, starts, the stay loosens, and steam and water will begin to leak through. A continuation of the heating

action softens the plate, so that it will be bulged downwards by the internal pressure in the boiler. The bulging enlarges the hole around the stay and if continued long enough the sheet will be pulled off the end of the stay, this action being assisted by the crown stay itself becoming soft.

53. The action that follows the overheating of a crown-sheet is therefore progressive. First, the sheet anneals and then begins to leak at the crown stays; next, the sheet begins to bag, or bulge, around the stays and finally it pulls away from them. After the first stay fails, those adjacent are liable to go immediately, as they are subjected to more than their share of the boiler pressure. If a large area of the sheet fails, the result will be a violent explosion, as the force of the explosion is in proportion to the size and suddenness of the initial rupture, and the volume and heat of the water in the boiler.

The portion of the crown-sheet that has been overheated is easily identified by the water side being black, all of the scale having been burned off. The blackened portion of the sheet will be surrounded by the rusty, scale-covered area that was covered by water, so that the area of the overheated portion as well as the high-water line will be plainly shown.

54. Reason for Violence of Explosion.—The temperature at which water will begin to turn into steam depends on the pressure at which the water is subjected. At atmospheric pressure, about 15 pounds per square inch, water will begin to turn into steam if it has a temperature of 212° F. If the pressure was suddenly and considerably reduced on water at this temperature the whole body of water would turn into steam. At a pressure of 200 pounds to the square inch, the water in the boiler will boil when its temperature reaches 388° F. Now if the crown-sheet ruptures suddenly over a wide area, the water in the boiler at, say, 388° F. is so far above its boiling temperature at atmospheric pressure that every particle of water instantaneously flashes into steam and increases in volume about eighteen hundred times. The steam is unable to escape fast enough from the boiler so that the result is a tremendous increase in pressure far above the pressure the boiler is designed to withstand. It is

this high pressure that produces the disastrous results that often follow boiler explosions.

**55. Clean Heating Surfaces.**—Another important item in the care of a boiler is to see that all heating surfaces are clean on both the inside and the outside. The interior of the boiler can be kept reasonably clean by frequently washing it out. All the exterior heating surfaces should be kept clear of soot, etc., because such things obstruct the transmission of the heat. Tubes and flues that are plugged, or stopped up, will materially affect the steaming of the locomotive, because they not only reduce the effective heating surface but they also retard to a great extent the draft on the fire.

Tests have proven that with one-half of the superheater flues plugged, the performance of the locomotive was reduced to that of a saturated-steam locomotive, with an increase in fuel consumption of 25 per cent. It has also been shown that with one hundred small tubes plugged the increase in fuel consumption is nearly 50 per cent.

This shows that the cleaning of the tubes and the flues as well as the other heating surfaces should receive careful attention. To insure economical operation, the tubes and flues, especially the superheater flues, should be blown out at the end of each trip. In bad-water districts if the boiler is not washed out as frequently as it should be, scale will form a coating over the surfaces and is liable to cause serious trouble. If the scale should become very heavy, the heat will not be carried away by the water fast enough to prevent a rise in the temperature of the plate.

The increase in temperature beyond a certain limit will cause the plate to become more or less seriously distorted. Unless cared for and remedied promptly, the plate will be affected to such an extent as to make a rupture very likely.

**56. Blowing Out.**—In no case should a boiler be blown out with a full pressure of steam, because the sudden reduction of pressure is almost sure to cause excessive strains on parts of the boiler as well as cause scale to form on the heating surfaces.

To blow out the water, the pressure should be reduced to about 20 pounds per square inch before the blow-off cock is opened. A boiler should not be refilled with cold water until it has cooled off, because the sudden contraction of the several parts is sure to result in leaky seams or tubes.

**57. Use of Blower.**—Care should be exercised in the use of the blower, especially in locomotives without a brick arch. The improper use of the blower draws an excessive amount of cold air into the firebox and directly against the tubes and the flues. When the fire is low, or when there are holes in it, the draft caused by the blower will cool off the firebox sheets and tubes. The contraction that results will usually start the tubes leaking to an extent that will in some cases cause an engine failure.

The improper use of the blower will also cause leaks at the staybolts. It is at the ash-pit, however, that the most damage is done by the abuse of the blower. Usually those in charge of the dumping and the cleaning of the fire think more of their own comfort than the care of the boiler, and use the blower strong enough to take all smoke, gases, and fine ashes away from the firebox. This causes a strong current of cold air to pass through the firebox and into the tubes, and the sudden contraction of the various parts invariably causes leaky tubes.

**58. Honeycomb.**—Care should be exercised in the handling of a locomotive boiler that small masses of linkers, called honeycomb, are not allowed to form on the firebox sheets, especially on the heads of the crown stays and on the ends of the tubes and flues. Honeycomb is caused by the foreign matter in the coal adhering to those parts of the firebox surfaces which are exposed to the direct action of the flames and which are not properly covered with water on the other side. The linker should be knocked off with a long rod through the fire-door, as when on the tube-sheet it obstructs the flow of hot gases through the tubes and reduces their effectiveness the same as if they were plugged.

**59. Even Firebox Temperature.**—When firing, it is important that the fireman maintain a firebox temperature as nearly

uniform as possible. This avoids the alternate rise and fall in temperature, as the fire is first forced and then allowed to burn down. A high firebox temperature causes the tubes to expand rapidly, and when the cold currents of air strike them, they suddenly contract. The alternate expansion and contraction soon causes loose tubes and flues and, very often, engine failures. With oil-burning locomotives, on account of the high firebox temperature when the engine is working, care should be taken to see that the dampers are immediately closed when the fire is reduced. This prevents cold air from striking the hot surfaces of the firebox. The possibilities of damage to the firebox are much greater with an oil-burning locomotive than in the case of a coal burner.

60. **Leaks.**—All leaks in the firebox, especially around the foundation ring, should be repaired as soon as possible, because the leakage represents a considerable loss of fuel. The steam also has a tendency to unite chemically with the sulphur in the coal and attack the metal in the sheets. All steam leaks into the front end from the steam pipes and the superheater should be attended to promptly. The leakage of steam causes a cutting action that soon wears away the parts it comes in contact with, and also reduces the vacuum in the smokebox. The smokebox door and the steam-pipe connections through the smokebox should be as nearly air-tight as possible so as to prevent the air from entering the smokebox and destroying the vacuum created by the action of the exhaust.

#### ACCIDENT INVESTIGATION REPORT

61. **Copy of Form.**—A copy of the form used by the inspectors of the Bureau of Locomotive Inspection of the Interstate Commerce Commission in reporting accidents resulting from boiler failures is herewith given. The form has been partly filled in to show how it is to be compiled in reporting an accident, which in this case is assumed to be a failure of a crown-sheet due to low water.

Form No. 25.

File No. \_\_\_\_\_

### INTERSTATE COMMERCE COMMISSION BUREAU OF LOCOMOTIVE INSPECTION

#### Accident Investigation Report

Attention is directed to the following extract from the law under which this investigation was made:

"Neither said report nor any report of said investigation nor any part thereof shall be admitted as evidence or used for any purpose in any suit or action for damages growing out of any matter mentioned in said report or investigation."

Investigation made at \_\_\_\_\_ 19\_\_\_\_

Name of railroad \_\_\_\_\_ A. B. C.

Initials of locomotive \_\_\_\_\_ A. B. C. Number \_\_\_\_\_ 503

Type \_\_\_\_\_ 2-8-2 \_\_\_\_\_ Steam pressure \_\_\_\_\_ 185 lbs.

Class of service \_\_\_\_\_ Freight \_\_\_\_\_ Speed \_\_\_\_\_ 35 m. p. h.

Operated by \_\_\_\_\_ A. B. C. Railroad Company.

Nature of accident \_\_\_\_\_ Crown sheet failure.

Place \_\_\_\_\_ Date \_\_\_\_\_

Time \_\_\_\_\_ Engineer \_\_\_\_\_

Residence \_\_\_\_\_

Fireman \_\_\_\_\_

Residence \_\_\_\_\_

Conductor \_\_\_\_\_

Residence \_\_\_\_\_



The crown sheet was found to have been overheated in spots. At the front end, the heat showed back to between the fourth and fifth crown stays from the flue sheet at center of crown sheet, and from this point tapered toward the flue sheet at both sides and downwards to the first bolt from the flue sheet and the third bolt from the center, then extended downwards to the tenth bolt on each side of the center. At the back end of the firebox the heat showed between the two center rows of radial stays from the thirteenth transverse row from the door sheet back to the second row from the door sheet, where it widened out to a distance of about 20 inches on both sides of the center.

The line of demarcation at the flue sheet showed about 10 inches below the highest part of the crown sheet and tapered back as per the taper in the crown sheet, which was 4 inches.

The door sheet pulled from four staybolts in the center at the top and the door sheet flange came down about 5 inches at the lowest point.

The riveted seam at the top of the flue sheet was sprung and the welded beads on the top row of the superheater flues, the top row of fire tubes, and the tubes between the top and second rows of superheater tubes, were broken loose.

The irregular demarcation by the heat was evidently due to upward circulation through the syphons depositing water on the crown sheet after the general water level had receded below the crown sheet.

#### WATER GLASS AND GAUGE COCKS:

The bottom water-glass mounting and the gauge cocks were applied in boiler back head.

The gasket had been removed from the nut on the bottom of the tubular water glass and with this nut screwed down on the water-glass mounting, the lowest reading of the water glass was  $3\frac{1}{2}$  inches above the highest part of the crown sheet.

The bottom gauge cock was  $3\frac{1}{2}$  inches above the highest part of the crown sheet.

#### SAFETY VALVES:

The safety valves were removed and placed on locomotive 504, and were left there after being tested.

#### INJECTORS:

The injectors were removed and placed on locomotive 505 where they were left after being tested.

#### FIRE DOOR:

The boiler was equipped with a mechanically-operated fire door.

#### INSPECTION AND REPAIRS:

Locomotive 503 was last given general repairs in August, 19 at company's shop, at which time this firebox was applied, and since that time to April 1, 19-- the locomotive had made 99,423 miles. The last annual inspection was made at August 1, 19--. The last monthly inspection was made at.....enginehouse April 15, 19--. This report had been removed from the cab case and was in the roundhouse foreman's office. All firebox sheets, syphons, and flues were reported in good condition.

#### Contributory defects found:

There were no contributory defects found during this investigation; however, all the apparatuses had been removed from the boiler and examined by the railroad inspectors before this inspection was made.

#### General condition of locomotive:

Good.

#### Cause of accident:

Crown sheet failure caused by overheating due to low water.

Inspector

Inspector

#### Remarks:

#### WASHING OUT BOILERS

62. The washing out of a locomotive boiler is a most important item, as successful maintenance and boiler efficiency depend largely on the care that is taken in washing out. Nearly all water contains more or less impurities, which settle to the bottom when the water is boiled. In the case of a boiler, the impurities settle on the tubes and the firebox sheets or at the bottom of the water legs, and, unless removed promptly, soon cause the formation of a hard scale. The scale reduces the efficiency of the

heating surface to a considerable extent, because the heat must penetrate the scale before it reaches the water. Tests have shown that a deposit of scale  $\frac{1}{2}$  inch thick results in a loss of 15 per cent. of the fuel burned. Another result of scale, especially on the firebox sheets, is the liability of the sheet to become overheated and collapse.

Washout plugs are provided to facilitate the washing out of a boiler and are placed in the most advantageous places. A certain number are placed in the back head above the crown-sheet, and also at about the same level in the wrapper sheet. Other plugs are located in the boiler shell on each side slightly above the top of the flues and in the front tube-sheet, as well as at each outside corner of the firebox and in the water legs. Washout holes closed by washout covers are also provided in the belly of the boiler, one being often placed in each course.

When washing out a boiler, all washout plugs and covers are first removed. A suitable nozzle is inserted in each of the various washout holes in the back head and in the wrapper sheet, and the crown-sheet is then washed off, warm water under a pressure of at least 50 pounds being used. Next, the flues are washed down by inserting the nozzle in the holes in the boiler shell. By this time, the sediment has been washed into the water legs and the belly of the boiler, and any that has not already escaped through the openings at the latter point can be washed out by inserting the nozzle in the holes in the front tube-sheet. The water legs can be cleaned out by forcing water into the holes provided there.

63. It will be noted that the system used in washing out a boiler is to start at the higher washout plugs and wash the sediment into the lower parts. Scrapers are used when sediment cannot be removed by washing. A large mass of sediment or scale on the crown-sheet or the water legs, which will cause the sheet to be burned and which cannot be dislodged by the ordinary methods, must be removed at all costs, even to the extent of taking out a number of crown stays or staybolts to do so.

#### TESTING OF BOILERS

64. **Method of Test.**—The Interstate Commerce Commission prescribes that every boiler before being put into service and at least every 12 months thereafter shall be subjected to hydrostatic pressure 25 per cent. above the working steam pressure.

The test is made by filling the boiler with warm water and then raising the pressure of the water by means of a force pump or an injector. When the boiler is being filled with water, all air is expelled by removing a plug or by opening a valve in the highest part of the boiler; the pressure can be applied more quickly and easily when there is no air present. The safety valves are either removed and plugs inserted in their places or else they are closed and clamped. An accurate test gauge is applied to the boiler and the pressure must be watched closely to see that the prescribed testing pressure is not exceeded, as it is very easy to strain, unduly, some part of the boiler.

Cold water is not satisfactory for testing, because the boiler plates are cold and contracted to a minimum and leaks will appear. A boiler that is in good condition and tight under steam will usually show numerous leaks when full of cold water under pressure, so that the use of cold water makes the test unnecessarily severe.

After all defects, such as leaky seams and broken staybolts and crown stays have been taken care of, the boiler is fired up and the pressure raised to not less than the working pressure so as to determine the permanency of the repairs made.

Broken staybolts are more easily detected when the boiler is under pressure, as when making a hydraulic test, than when it is not. The reason is that the broken ends are now separated slightly, whereas when the boiler is not under pressure the broken ends are in contact, thus giving a sound like a good staybolt.

#### POOR-STEAMING LOCOMOTIVES

65. **Causes of Poor Steaming.**—A poor-steaming locomotive is one in which the boiler will not generate steam fast enough to meet the requirements of service. With such a locomotive

it is very difficult to maintain full boiler pressure except under very favorable conditions of operation.

The modern locomotive is designed and proportioned in accordance with experience and observation, and therefore when an engine steams badly, the trouble should not be too hastily charged to faulty designing. The fault may occasionally be in the design, such as cylinders too large for the amount of heating surface, insufficient water spaces, or the diaphragm too close to the tube-sheet, but it is far more likely to be due to other causes over which the engineer has control. Aside from faulty design, there are three general causes that will make a locomotive steam poorly: (1) Improper or insufficient draft; (2) the heat of the fire not being fully utilized; and (3) poor management on the part of those in the cab.

**66. Insufficient Draft.**—Insufficient draft may be due either to some obstruction in the firebox, tubes, smokebox, or stack, or to insufficient vacuum being formed in the smokebox by the exhaust steam, this meaning that the difference between the atmospheric pressure and the smokebox pressure is not enough to create the proper draft, or to the fact that, while a sufficient vacuum may be formed by the exhaust steam, its effect on the fire is partly destroyed through some defect in the draft apparatus. The obstruction to the draft may perhaps be in the grates, which may be fitted so close as to prevent the admission of a sufficient quantity of air through the fire.

Some of the tubes may be stopped up, owing to careless firing or to poor regulating of the draft appliances. If the draft is weak, ashes and cinders will gradually accumulate in the tubes until finally they become stopped up.

If the draft is too strong, large cinders will be drawn into the tubes and flues and produce the same effect as when the draft is too weak. Plugged tubes and flues reduce the heating surface of the boiler and hence its steam-generating capacity. If the tubes and flues are obstructed at the firebox end by honeycomb, the effect will be the same as if the tubes were plugged.

If the firebox is reasonably clean and there are no ashes or cinders in the tubes and flues, the cause of the poor draft may be

in the smokebox. The diaphragm or deflector plates may be too close to the tube-sheet, the diaphragm apron or damper may be too low, the netting may be clogged or the smokebox may be filled up with cinders. The foregoing shows that as little obstruction as possible should be imposed on the flow of the gases to the atmosphere, other than what is necessary to produce a uniformity of draft over the whole heating surface.

**67. Measurement of Draft.**—The draft is measured by a draft gauge, a view of which is shown in Fig. 24. This device consists of a U-shaped tube containing water, and having a sliding scale graduated in inches, the whole being suitably mounted on a part *b*. The upper end of the leg *a* of the tube is connected to and opens into the smokebox so that the water within the tube is subject to smokebox pressure, and the end of the other leg *c* is open and exposed to atmospheric pressure. The water in both legs will stand at the same level when the pressures in the legs are equal, as when the locomotive is not working. With the locomotive working, the draft reduces the pressure in the smokebox and on the water in leg *a*, and the greater pressure of the atmosphere acting on the water in leg *c* raises the water in leg *a*.

The draft is measured in inches of water as follows: The sliding scale is moved so that the zero reading is in line with the lower water level, as shown, and the figure which then comes opposite to the higher water level is noted, which in Fig. 24 is 4. With this reading, the draft would be said to be equal to 4 inches of water, this meaning that the difference between the pressure of the atmosphere and the pressure in the smokebox is sufficient to maintain a column of water 4 inches high. A pressure equal to 1 inch of water in a draft gauge is equal to about  $\frac{1}{2}$  ounce, so that 4 inches would be equal to about 2 ounces of pressure per square inch.

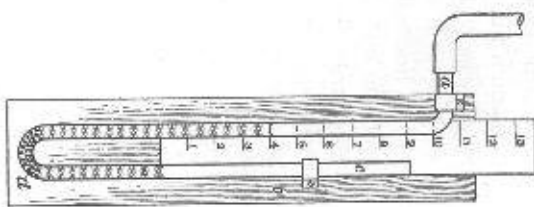

FIG. 24

In locomotive practice the draft varies between 4 and 10 inches of water. The shot *d* in the bottom of the tube prevent a too rapid movement of the water due to change in pressure.

**68. Insufficient Vacuum.**—The firebox and the tubes may be clean and the smokebox appliances may be properly adjusted, but still the engine may not steam. The cause may then be due to insufficient vacuum being formed in the smokebox. Insufficient vacuum may be due to any of the following causes: The nozzle may be so large that the exhaust steam will pass through the smokebox at a very low velocity; the exhaust pipe may be set out of line with the center of the stack, thus throwing the jet more on one side of the stack than the other, or part of the jet may strike the inside of the smokebox proper, or the stack extension may be so set as to have the same effect on the exhaust jet as if the exhaust pipe were out of line.

The principal causes, however, of an insufficient vacuum in the smokebox are air leaks in the smokebox or steam leaks from the steam pipes and superheater units into the smokebox. If the door of the smokebox is improperly set and air can enter through the joints, the action of the exhaust jet will draw air through the openings and less will come through the fire.

**69. Poor Circulation.**—Another cause of a poor-steaming engine is a poor circulation of water, or a dirty boiler with the heating surfaces covered with mud and scale. To promote circulation, the feedwater should enter the boiler near the front tube-sheet so that it can work along to the tubes and the flues to the hot surfaces and rise with the steam.

**70. Poor Management.**—Another cause of a poor-steaming engine is poor management and lack of cooperation on the part of those in the cab. To obtain the best results, the firing and feeding should be carried on according to approved methods. The use of the injector has a very important effect on the steaming of a locomotive. The best fireman cannot maintain a good head of steam if the engineer insists on flooding the boiler. Neither can the required amount of steam be produced if the engineer works the engine at a long cut-off when a shorter one obtains the same if not better results.

## CALCULATING STRENGTH OF BOILER JOINTS

### DEFINITIONS RELATING TO BOILER PLATE

**71. Tensile Strength of Boiler Plate.**—The tensile strength of boiler plate is determined by actual test in a testing machine, and the unit by which it is measured is the force, in pounds, necessary to pull apart a piece of plate of a cross-sectional area of 1 square inch, as indicated in Fig. 25.

The square inch may, however, be in any form as long as it contains a square inch of metal; that is, it may be 1 inch each way, or it may be wider and thinner, as 2 inches wide and  $\frac{1}{2}$  inch thick. Increasing the cross-sectional area of a piece of plate to 2 square inches doubles the amount of the metal, and naturally doubles the tensile strength, so that tensile strength depends on cross-sectional area.

The dimensions of a standard test piece are shown in Fig. 26. The recommended strength for boiler plate used in the boiler shell is a tensile strength of 60,000 pounds per square inch of

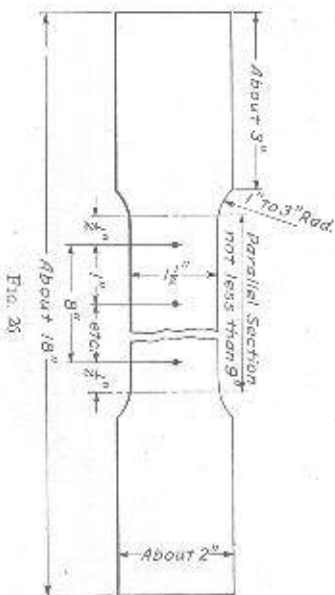
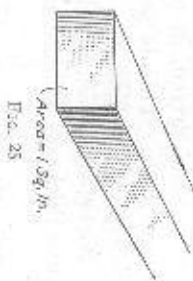

cross-sectional area but a variation of 5,000 pounds either way is permissible. When the tensile strength is unknown, a value of 50,000 pounds is to be used. The recommended tensile strength for firebox steel is 57,000 pounds, and the same variation is permitted as with boiler plate.

As yet the A. A. R. has no specifications for other than carbon-steel boiler plate. Nickel-steel boiler plate as well as other alloy-steel boiler plate have a much higher tensile strength. For example, a nickel-steel boiler shell has a minimum tensile strength of 75,000 pounds per square inch and the firebox plate a tensile strength of 65,000 pounds per square inch. According to the manufacturer's tests the shearing strength of nickel-steel rivets, hand driven, in most cases exceeds 65,000 pounds per square inch. This is permissible according to Rule 6 of the Federal regulations.

Nickel-steel boiler shells permit of higher pressures with the same thickness of plate as compared with carbon-steel shells.

**72. Elastic Limit.**—The elastic limit is the point at which the test piece of boiler plate will not return to its original length when relieved of tension during a test. All metals will stretch when subjected to a pull, and if the pull is not too great the metal will return to its original length when the pull is removed. However, any pull in excess of a certain amount will stretch the metal beyond the limit of recovery and it will then not return to its original length. The elastic limit, or yield point, as it is sometimes called, must not be less than half the tensile strength. A pull in excess of the elastic limit affects the structure of the metal and weakens it so that the pressure in the boiler should never be permitted to rise to such a point that the pull on the plate exceeds the elastic limit. It is for this reason that the testing pressure of a boiler is restricted to about 25 per cent. above the working pressure.

**73. Elongation.**—Elongation is the amount the test piece stretches before it breaks, and is determined by placing the ends together and measuring the distance between two prick-punch marks that were originally 8 inches apart.

The proper amount of elongation insures the flanging of the plates without materially affecting the strength of the metal.

The foregoing definitions do not apply to the special alloy steels that contain nickel, etc., used in some modern boilers.

#### DEFINITIONS RELATING TO JOINTS

**74. Types of joints.**—There are two types of joints used in locomotive boilers, namely, the lap joint and the butt joint. A lap joint is one in which one edge of the plate laps over the

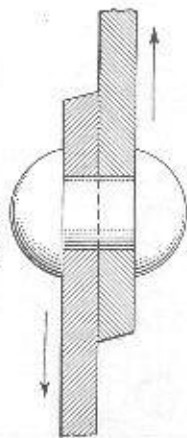

FIG. 27

other, as in Fig. 27. A butt joint is one in which the edges butt against each other and are held in contact by welds or cover-plates, as in Fig. 28.

**75. Single- and Double-Riveted Lap Joints.**—A single-riveted lap joint is one in which the edges of the plate are held together by a single row of rivets, whereas a double-riveted lap

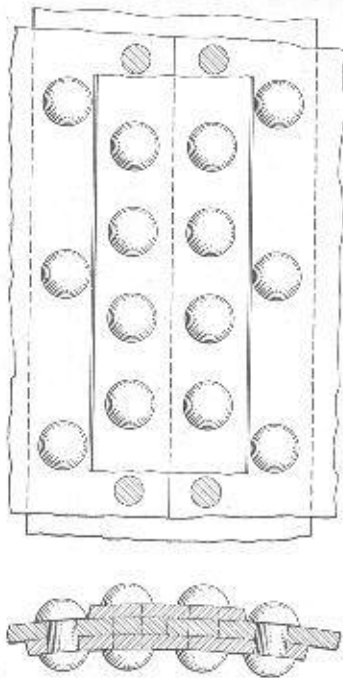

FIG. 28

joint employs two rows of rivets, as in Fig. 29. The various courses of the cylindrical part of a boiler are usually joined together by double-riveted lap joints.

**76. Triple- and Quadruple-Riveted Joints.**—A triple-riveted butt joint, Fig. 30, is identified by having three rows of rivets on

each side of the seam, and a quadruple-riveted butt joint is one with four rows of rivets on each side of the seam. The latter is generally used in the longitudinal seams of locomotive boilers.

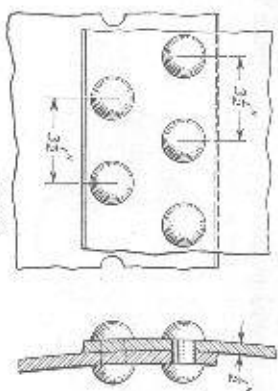

FIG. 29

**77. Pitch of Rivets.**—Pitch of rivets is defined as the distance between the centers of adjacent rivet holes, as in Fig. 31.

**78. Back Pitch.**—Back pitch is the distance between two rows of rivets, one on each side of the joint.

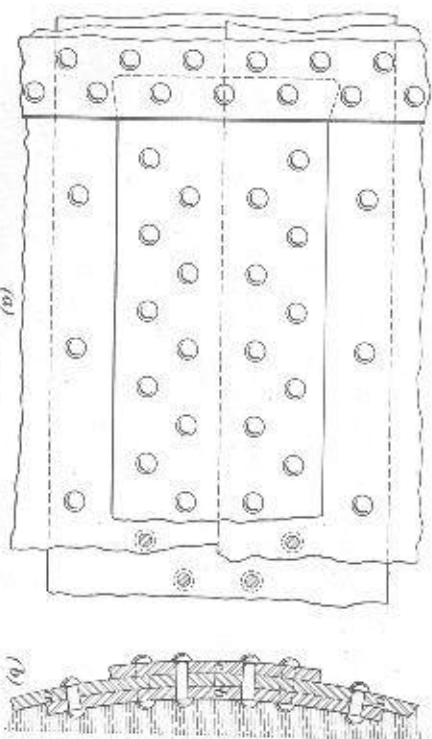

FIG. 30

**79. Rivet in Single Shear.**—A rivet is in single shear when it is possible to shear it in only one place, as in Fig. 32. A pull on the plates as shown by the arrows will cause the rivets to shear, as shown, only along the line *ab*.

**80. Rivet in Double Shear.**—A rivet is in double shear when it will shear in two places, as at *c* and *d*, Fig. 33. A rivet in single shear involves two plates; one in double shear involves three plates.

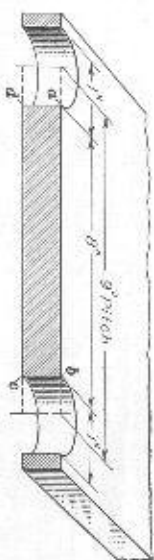

FIG. 31

**81. Relative Strength of Rivets in Single and Double Shear.**—A rivet in double shear has twice the strength of a

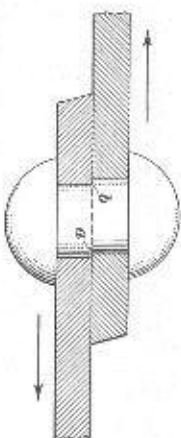

FIG. 32

similar one in single shear, because it has to be severed at two points simultaneously. In Canada, however, a rivet in double shear is considered as being only  $1\frac{1}{2}$  times as strong as one in single shear.

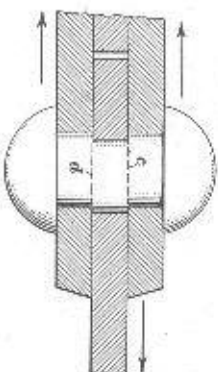

FIG. 33

**82. Rule for Calculating Tensile Strength of Plate.**—The rule used to calculate the tensile strength of a piece of boiler plate is as follows:

**Rule.**—To find the tensile strength of plate, multiply the cross-sectional area of the plate, in square inches, found by multiplying its width by its thickness, by the unit of tensile strength, here assumed to be 60,000 pounds for each square inch of cross-sectional area.



FIG. 34

**EXAMPLE.**—What is the tensile strength of the piece of boiler plate shown in Fig. 34, which has a width of 8 inches and a thickness of  $\frac{5}{8}$  inch, the stress being applied in the direction of the arrows?

**SOLUTION.**—The cross-sectional area of the plate is  $8 \times \frac{5}{8} = 5$  sq. in. As each square inch has a tensile strength of 60,000 lb., 5 sq. in. will have a tensile strength of  $60,000 \times 5 = 300,000$  lb.

**83. Calculating Tensile Strength of Plate Between Rivet Holes.**—The drilling or punching of rivet holes in a plate of course weakens it most on a line through the centers of the rows of rivets; the strength of the remainder of the plate remains unimpaired. The only difficulty met with when calculating the tensile strength of a plate in which holes are drilled, is to find the area of the section of plate that remains between any two adjacent holes.

The method of finding this area can be more readily understood from Fig. 31, which shows the plate broken off on a line through the centers of the rivet holes and the broken piece removed. Drilling the rivet holes reduces the length of solid plate between the centers of any two adjacent holes by one-half the diameter of two rivet holes, or in this case by 1 inch. The length of any section of plate between two adjacent holes then becomes 9 inches less 1 inch, or 8 inches, and as the plate is  $\frac{5}{8}$  inch thick, the cross-sectional area *abcd* between the holes is  $8 \times \frac{5}{8} = 4$  square inches. The unit of tensile strength assumed is 60,000 pounds for each square inch of cross-sectional area, so that the plate has a strength, on a line through the rivet holes, of  $4 \times 60,000$ , or 240,000, pounds. It is necessary to calculate only the strength of the plate between two adjacent holes, because as the pitch of all holes in any one row is the same the plate will be weakened

the same amount between every two holes. Theoretically, the plate will fail simultaneously on a line through the centers of all holes. The following rule can be deduced from the foregoing:

**Rule.**—To find the tensile strength of a plate between rivet holes, subtract one-half the diameter of two rivet holes, or the diameter of one rivet hole, from the pitch and multiply the result by the thickness of the plate and the unit of tensile strength.

**84. Rule for Calculating Efficiency of Plate.**—The efficiency of the plate is its tensile strength after drilling the rivet holes, as compared with its strength before, and is found by dividing the former value by the latter. This can be summarized in a rule as follows:

**Rule I.**—To calculate, in per cent, the efficiency of a plate in which rivet holes have been drilled, divide the tensile strength of the plate after the holes were drilled, by its tensile strength before the holes were drilled and multiply the result by 100.

**EXAMPLE.**—What is the efficiency of the boiler plate shown in Fig. 31? **SOLUTION.**—The tensile strength after the holes were drilled has already been shown to be 240,000 pounds. The ultimate tensile strength, according to the rule in Art. 82, is 9 inches multiplied by  $\frac{5}{8}$  inch, multiplied by 60,000 pounds. The result is 270,000 pounds. Hence, the efficiency of the plate is  $\frac{240,000}{270,000} \times 100$  or 88.8 per cent. The plate has then been weakened 11.2 per cent.

The efficiency of the plate can also be calculated from the following rule, which involves less work than the one just given:

**Rule II.**—To calculate the efficiency of the plate subtract the diameter of one rivet hole from the pitch, then divide by the pitch and multiply by 100.

For example, the efficiency of the plate shown in Fig. 31 equals  $\frac{9-1}{9} \times 100 = 88.8$  per cent.

This rule is derived from the rule just given by canceling out similar quantities.

Thus, efficiency of plate  
(pitch—diameter of one rivet hole) × thickness of plate

$$= \frac{\text{pitch} \times \text{thickness of plate} \times \text{unit of tensile strength}}{\text{unit of tensile strength}} \times 100$$

It will be noted that thickness of plate and unit of tensile strength cancel out, as each appears above and below the line, leaving the rule as stated.

**85. Calculating Shearing Strength of Rivets.**—The unit of shearing strength of rivets will be taken as 44,000 pounds for one square inch of cross-sectional area; the driven diameter of the rivet is always taken when calculating the cross-sectional area. The shearing strength of a rivet, like the tensile strength of a piece of plate, depends on the amount of metal in its cross-sectional area, so that the following rule governs:

**Rule.**—To calculate the shearing strength of a rivet, multiply its cross-sectional area, by the unit of shearing strength.

**EXAMPLE.**—What is the shearing strength of a rivet of a driven diameter of 1 inch?

**SOLUTION.**—The cross-sectional area of the rivet is found by multiplying the diameter by itself and by .7854. Hence, the area is  $1 \times 1 \times .7854 = .7854$  sq. in. Then the shearing strength of the rivet is  $.7854 \times 44,000 = 34,557$  lb.

**86. Assumption on Which Rules Are Based.**—It will be evident from the foregoing that the rules relating to the strength of plates and rivets are based on the assumption that the strength of a plate or a rivet is proportional to the amount of metal in its cross-section. Doubling the cross-sectional area doubles the strength; halving it reduces the strength a corresponding amount.

#### ANALYSIS OF STRENGTH OF LAP JOINTS

**87. Factors on Which Strength of Joint Depends.**—The strength of any joint depends on the pitch of the rivets, on the shearing strength of the rivets, and on the tensile strength of the plate. The larger these factors the stronger the joint. However, there is a limit to the pitch, as too great a pitch will impair the tightness of the joint. The joint can never be as strong as

the plate itself but, in an ideal joint, the pitch and the diameter of the rivets should be so arranged as to make the strength of the plate between rivet holes of approximately the same strength as the shearing stress of the rivets.

**88. Calculating Strength of Plate, Single-Riveted Lap Joint.**—The maximum strain that the plate will withstand at the weakest point of the joint shown in Fig. 35, which is through the center of the rivet holes, can be calculated from the rule in

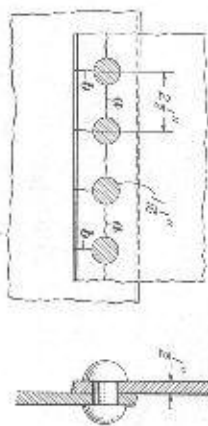

FIG. 35

Art. 83. The pitch is  $2\frac{1}{2}$  inches, the diameter of rivets is  $1\frac{1}{4}$  inches, and the thickness of the plate is  $\frac{1}{2}$  inch, so that

$$\left(\text{Pitch—diameter of one rivet hole}\right) \times \text{thickness of plate} \times \text{unit of tensile strength} = \text{strength of plate, or}$$

$$\left(2\frac{1}{2} - 1\frac{1}{4}\right) \times \frac{1}{2} \times 60,000 = 43,125 \text{ pounds.}$$

**89. Calculating Strength of Rivets, Single-Riveted Lap Joint.**—The shearing strength of the rivets can be calculated from the rule in Art. 85, it being noted that one-half the diameter of two rivets, or the diameter of one rivet, is to be considered when calculating the cross-sectional area. From this rule,

Cross-sectional area of one rivet × unit of shearing stress = shearing strength of rivet, or

$$\frac{1}{2} \times \frac{1}{2} \times .7854 \times 44,000 = 39,010 \text{ pounds}$$

As the shearing resistance of the rivets is less than the tensile strength of the plate, the rivets will all shear off first, that is, the rivets constitute the weak part of the joint.

If the rivets are too large for the pitch, the plate will fail along the line *a*, Fig. 35; if the holes are drilled too close to the edge

of the plate, the plate will fail in front of the rivets along the lines *b*. But if the distance from the center of a rivet to the edge of the plate is made  $1\frac{1}{2}$  times the diameter of the rivet, the latter failure is extremely unlikely to occur.

**90. Efficiency of Joint.**—The efficiency of the joint is the comparison between the weakest part of the joint and the strength of the solid plate expressed in per cent. The strength of the solid section of plate from the rule in Art. 82 is equal to Cross-sectional area of plate  $\times$  unit of tensile strength, or

$$24 \times \frac{1}{2} \times 60,000 = 75,000 \text{ pounds}$$

The strength of the weakest part of the joint was shown to be 39,010 pounds. Hence,  $\frac{39,010}{75,000} \times 100 = 52.6$  per cent, or a little over one-half the strength of the plate.

Therefore, the following rule can be used to calculate the efficiency of a joint:

**Rule.**—*Divide the strength of the weakest part of joint by the ultimate strength of the plate and multiply the result by 100.*

**91. Calculating Strength of Plate, Double-Riveted Lap Joint.**—The strength of the plate at each row of rivets of the double-riveted lap joint, Fig. 29, is the same because the pitch and the size of the rivets in each row are identical. Hence, it is necessary only to consider the strength at one row. The first row will be taken. From the rule in Art. 83, the strength of the plate is

$$(32 - 1\frac{1}{8}) \times 4 \times 60,000 = 73,125 \text{ pounds}$$

**92. Calculating Strength of Rivets, Double-Riveted Lap Joint.**—The shearing resistance offered by the rivets can be calculated from the rule in Art. 85, it being remembered that there are two rivets to be sheared off, that is, half of two rivets in one row and a whole rivet in another row. Hence, the shearing strength of the rivets is

$$1\frac{1}{2} \times 1\frac{1}{2} \times 7854 \times 2 \times 41,000 = 78,020 \text{ pounds}$$

**93. Efficiency of Joint.**—The strength of the solid section of plate, from the rule in Art. 82, equals

$$34 \times \frac{1}{2} \times 60,000 = 105,000 \text{ pounds}$$

The strength of the weakest part of the joint was found to be 73,125 pounds. Hence the efficiency of the joint, according to the rule in Art. 90, is equal to

$$\frac{73,125}{105,000} \times 100 = 69.6 \text{ per cent. of the strength of the solid plate.}$$

**94. Reason for Greater Efficiency of Double-Riveted Lap Joint.**—The reason for the greater efficiency of the double-riveted lap joint is the employment of two rows of rivets; this permits of a greater distance between rivet holes, or greater pitch. The greater the pitch the less the strength of the plate is affected along the line of the rivet holes.

The reason for staggering the rivets is to give a tighter joint, but the joint is no stronger than if the rivets of one row were directly in line with those of the other row.

#### ANALYSIS OF BUTT JOINTS

**95. Points of Failure.**—On account of its construction the quadruple-riveted butt joint shown in Fig. 36 has many more possible points of failure than a double-riveted lap joint. The joint may fail in the following ways:

- (1) The plate may fail between the rivets in the outer row, as at *a*, view (*b*). This failure affects no other part of the joint.
- (2) The plate may fail between the rivets in the second row, or at *b*. The plate before it can fail there must also shear off the other row of rivets.
- (3) The plate may fail between the rivets in the third row, or at *c*. Before the plate can fail here, it must also shear off the rivets in the two outer rows.
- (4) The two butt straps or coverplates may fail between the rivet holes in the inner row, but this failure will involve no other part of the joint.

**96. Length of Joint to be Considered.**—A longitudinal joint in a locomotive boiler is really about 6 feet in length, but when considering the strength of the seam it is unnecessary to take account of the whole length. To shorten the calculations it is

only necessary to take a length of joint equal to the greatest pitch, which is always found at the outer row of rivets in joints of this kind. In this case the greatest pitch is 19 inches, the tensile strength of the plate is taken as 55,000 pounds per square inch of cross-section, and the thickness of the boiler shell is 1 inch.

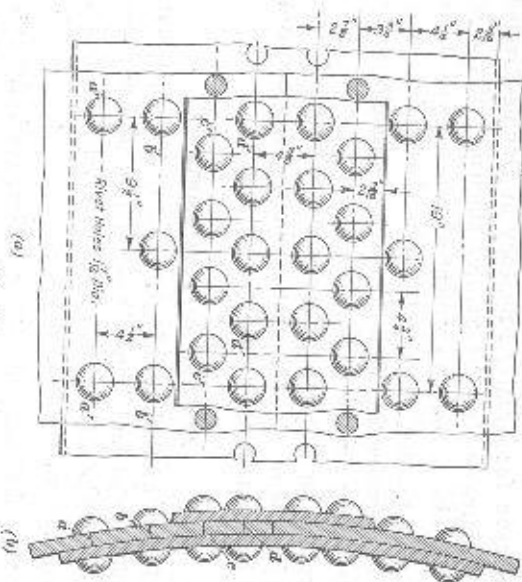

FIG. 36

97. **Strength of Joint at Outer Row of Rivets.**—From the rule in Art. 83, the strength of the plate at the outer row of rivets, Fig. 36, is

$$(19 - 1\frac{1}{8}) \times 1 \times 55,000 = 965,937 \text{ pounds}$$

98. **Strength of Joint at Second Row of Rivets.**—The resistance of the plate to failure at the second row of rivets, Fig. 36, is also found from the rule in Art. 83, it being noted that the length of the cross-section of plate here is shortened by the diameter of two rivet holes; that is, the two half-diameters of two rivets and the diameter of one. Hence, the strength of the plate at the second row of rivets is

$$19 - 2(1\frac{1}{8}) \times 1 \times 55,000 = 886,875 \text{ pounds}$$

To this must be added the shearing stress of two halves of one rivet, or a whole rivet, in the outer row, which according to the rule in Art. 85 is

$$1\frac{1}{8} \times 1\frac{1}{8} \times .7854 \times 44,000 = 71,412 \text{ pounds}$$

The total strength of the joint at the second row of rivets, then, is 886,875 + 71,412 or 958,287 pounds.

99. **Strength of Joint at Third Row of Rivets.**—The resistance offered by the plate at the third row of rivets, where the plate has four holes, according to the rule in Art. 83, is

$$19 - 4(1\frac{1}{8}) \times 1 \times 55,000 = 728,750 \text{ pounds}$$

To this must be added the resistance of three rivets in single shear. It has already been shown that the shearing stress of one rivet is equal to 71,412 pounds, hence  $71,412 \times 3 = 214,236$  pounds is the shearing stress of three rivets.

Therefore, the total strength of the joint at the third row of rivets is equal to 728,750 + 214,236 = 942,986 pounds.

100. **Strength of Coverplates at Inner Row of Rivets.**—It can be assumed that the two coverplates each  $\frac{3}{8}$  inch thick are equivalent to one plate  $1\frac{1}{2}$  inches thick. The diameters of four rivet holes are to be deducted from the pitch of 19 inches. Therefore, according to the rule in Art. 83, the strength of the coverplates is

$$[19 - 4(1\frac{1}{8})] \times 1\frac{1}{2} \times 55,000 = 1,093,125 \text{ pounds}$$

This value, as shown further on, is slightly more than that of the boiler plate.

101. **Purpose of Calculations.**—The sole purpose of the foregoing calculations is to ascertain where the lowest value comes, as at this point the joint will be the weakest. It is unnecessary to proceed further once it becomes evident that a higher value will be obtained. Consider, for example, a failure of the plate at the inner row of rivets. The rivet holes number the same as in the third row, hence the plate is of the same strength at both points. But before the plate can fail at the inner row, four additional rivets in double shear in the third row

must also fail. Hence, there is no need of proceeding further with the calculations.

**102. Weakest Part of Joint.**—In checking over the values obtained, which are shown in heavy type, it will be noticed that the lowest resistance to rupture is found in the plate between the rivet holes in the third row; the low resistance at this point will also result in the shearing off of the two outer rows of rivets. Hence, the plate throughout its entire length will rupture at that point. However, with locomotive boilers it is apparently assumed that the net section of the plate at the outer row of rivets is the weakest part of the joint. For this to hold true the joint must be designed with this fact in mind, otherwise the weakest part of the joint can be elsewhere.

**103. Efficiency of Joint.**—The tensile strength of the section of full plate, according to the rule in Art. 82, is

$$19 \times 1 \times 35,000 = 1,045,000 \text{ pounds}$$

Therefore, the efficiency of the joint, according to the rule in Art. 90, is the weakest value divided by the ultimate tensile strength or

$$\frac{942,986}{1,045,000} \times 100 = 90.2 \text{ per cent.}$$

**104. Efficiency of Joint at Outer Row of Rivets.**—The efficiency of the joint becomes the efficiency of the plate if the weakest part of the joint is assumed to be the net section of plate at the outer row of rivets. Hence, the rule for calculating the efficiency of the plate can in this case be used to calculate the efficiency of the joint. From Rule II, Art. 84, the efficiency equals

$$\frac{19 - 1\frac{1}{8}}{19} \times 100 = 92.4 \text{ per cent.}$$

The foregoing shows that when the efficiency of the joint is also the efficiency of the plate, the efficiency of the joint can be found from Rule II, Art. 84, which is used to calculate the efficiency of the plate. But when the efficiency of the plate is less

than the efficiency of the joint, as when the joint is reinforced by rivets in other rows, the efficiency of the joint must be calculated from the rule in Art. 90.

#### FORCE TENDING TO RUPTURE BOILER SHELL

**105. Area to Be Considered.**—According to the law of the resolution of forces, the force that tends to rupture a circular boiler shell is the same as the force that tends to rupture a boiler made up of a series of vertical and horizontal surfaces that can

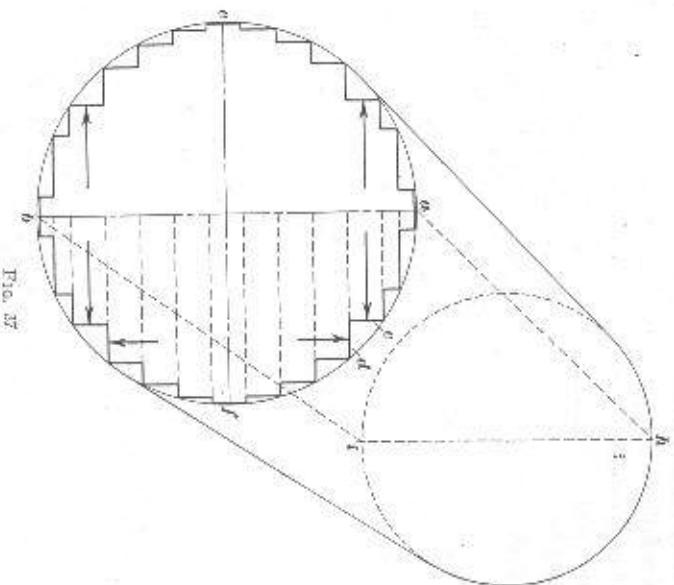

be enclosed by a circle of the same diameter as the boiler shell. This is illustrated in Fig. 37. Now the force of the steam that tends to separate one-half of the boiler from the other half at any two points, such as *a* and *b*, must be exerted at right angles to these points or in the direction of the arrows, and so acts against the vertical surfaces *c* of the boiler shell. The pressure that acts against the horizontal surfaces *d* tends to separate the boiler at

$e$  and  $f$  but not at  $a$  and  $b$ , and so does not have to be taken into account when considering the strain at  $a$  and  $b$ .

If the vertical surfaces  $c$  are now assumed to be laid one after the other against an imaginary plate  $ab$  in the center of the boiler, it will be evident that the area of these surfaces will be just equal to the complete area of the imaginary plate. It then follows that the area of the boiler against which the pressure is acting to rupture it along the lines  $ah$  and  $bi$  is equal to the area of this imaginary plate, this area being found by multiplying the diameter of the boiler by its length.

It then follows that the area to be taken when the strain along one line, such as  $ah$ , is being considered, is the upper half of the imaginary plate, which is equal to half the diameter of the boiler multiplied by its length. An area equal to one-half the area of the imaginary plate may then be assumed to be concerned with the strain along the line  $ah$ , and the other half with the strain along the line  $bi$ .

Although the imaginary plate is shown vertical in the boiler, yet the same reasoning applies if the plate is in any other position. In other words, the boiler may be considered as being made up of an infinite number of halves, each one endeavoring to separate itself from the other.

The steps shown in the boiler shell are purposely made large, but they may be considered as being made infinitely small, in which event they will conform very closely in shape to the circular shell of the boiler.

The following rule can be deduced from the foregoing:

**Rule.**—*The area to be taken when considering the strain at any lengthwise line along the boiler shell, is equal to the radius of the boiler multiplied by its length.*

**EXAMPLE.**—What area is to be taken when considering the strain on a line along a boiler that has a radius of 36 inches and a length of 120 inches?

**SOLUTION.**—From the rule, the area to be taken is  $36 \times 120 = 4,320$  square inches. Ans.

**106. Calculating Strain Tending to Rupture Boiler.**—When the area against which the pressure is acting in tending to rup-

ture the boiler shell is known, it is a simple matter to calculate the strain. To do so it is merely necessary to multiply this area by the boiler pressure. As already explained, the area to be taken when the strain on the boiler shell along any one lengthwise line is being considered, is a plate with a width equal to the radius of the boiler and a length equal to that of the boiler shell. It is then only necessary to multiply the length of the assumed plate by its width and by the boiler pressure to obtain the strain.

The pressure against the vertical surfaces in the left half of the boiler, Fig. 37, does not add anything to the force that tends to rupture the boiler at  $a$  and  $b$ . This part of the boiler may be considered as acting merely to resist the effort the right half is making to break away. To make the point clearer, suppose that two men pull in opposite directions on a chain, each exerting a force of 100 pounds. Then the force tending to break the chain is not 200 pounds, but 100 pounds. The effect is the same as if one end of the chain was fastened to a post and one man pulled with a force of 100 pounds.

The following rule can be formulated from the foregoing:

**Rule.**—*To find the strain that tends to rupture a boiler along any one lengthwise line, multiply the radius of the boiler by its length and by the boiler pressure.*

**EXAMPLE.**—What is the strain along a lengthwise line of a boiler with a diameter of 72 inches and a length of 120 inches, the steam pressure being 200 pounds per square inch?

**SOLUTION.**—The radius equals one-half the diameter, or  $\frac{1}{2} \times 72 = 36$  in. So from the rule just given, the strain is  $36 \times 120 \times 200 = 864,000$  pounds. Ans.

**107. Calculating Bursting Pressure.**—The bursting pressure of a boiler depends on the strength of the plate and the boiler pressure and is based on the assumption that it will fail at one point only or at the point of greatest weakness. It will therefore be evident that a boiler will burst when the internal pressure becomes equal to the tensile strength of the plate at the weakest point.

The first step in the calculation of the bursting pressure is to find the tensile strength of the plate at its weakest point. Let it

be assumed that the boiler has a diameter of 72 inches, and a length of 120 inches, with a thickness of plate of  $\frac{3}{8}$  inch. The tensile strength of the plate is taken as being equal to 60,000 pounds per square inch of cross-sectional area, which is assumed to be reduced by a joint efficiency of 80 per cent. Expressed as a decimal, 80 per cent. becomes .80.

From the rule in Art. 82, the tensile strength of the plate is

$$120 \times \frac{3}{8} \times 60,000 \times .80 = 3,600,000 \text{ pounds}$$

The second step is to find the area of the boiler to be taken when the strain along any line is being considered. This, according to the rule in Art. 90, is the area of an imaginary plate, equal to the product of the radius, 36 inches, and the length, 120 inches, or 4,320 square inches.

The pressure by which this area must be multiplied to obtain a pressure at one point of the boiler equal to the tensile strength of the plate, or 3,600,000 pounds, is found by dividing 3,600,000 by 4,320 square inches, or the area of the imaginary plate. The result, or 833 pounds, is then the bursting pressure. In other words, one-half the area of the imaginary plate multiplied by this pressure is equal to the cross-sectional area of the plate multiplied by the tensile strength.

The following rule can be deduced from the foregoing:

**Rule.**—To calculate the bursting pressure of a boiler multiply the minimum thickness of the plate by its tensile strength and by the efficiency of the joint expressed as a decimal, and divide the result by the radius of the shell.

**Example.**—What is the bursting pressure of a boiler with a plate thickness of  $\frac{3}{8}$  inch (.75), an inside diameter of 90 inches, an efficiency of longitudinal seam of 80 per cent, and a tensile strength of metal of 60,000 pounds per square inch of cross-sectional area?

**Solution.**—From the rule in Art. 82, the bursting pressure is

$$\frac{.75 \times 60,000 \times .80}{45} = 800 \text{ pounds per square inch. Ans.}$$

### 108. Relative Strengths of Girth and Longitudinal Joints.

A girth joint in a boiler is under only one-half the strain of a longitudinal joint of equal length, so that a double-riveted lap joint is usually all that is required for a girth joint.

The foregoing can be easily proved by the rules already given. A boiler diameter of 72 inches will be assumed with a length of joint of 1 inch and a boiler pressure of 100 pounds. With the dimensions kept small as with a joint 1 inch in length, the calculations will be shorter.

From the rule in Art. 106 the strain per inch of the longitudinal joint is

$$36 \times 1 \times 100 = 3,600 \text{ pounds}$$

The pull on the girth joint is equal to the product of the boiler pressure and the area of an imaginary tube-sheet in the course, so that it equals

$$72 \times 72 \times .7854 \times 100 = 407,151.36 \text{ pounds}$$

This pull is distributed over a length equal to the circumference of the boiler, which is

$$72 \times 3.1416 = 226.1952 \text{ inches}$$

Therefore, the pull on 1 inch of the joint is

$$407,151.3600 \div 226.1952 = 1,800 \text{ pounds,}$$

or just one-half of the strain per inch of longitudinal joint.

A much bricker calculation can be made by assuming a pressure of 1 pound and a length of joint of 1 inch and also using a letter, as  $D$ , for the diameter. The strain on the longitudinal joint then becomes

$$\frac{D}{2}, \text{ or the radius of the shell}$$

The pull on the entire length of the girth joint becomes

$$D \times D \times .7854$$

and the pull on 1 inch of the girth joint equals

$$\frac{D \times D \times .7854}{D} = \frac{D}{4}$$

$$D \times 3.1416 = 4$$

Therefore, the last result is just one-half of the first.

**109. Factor of Safety.**—The factor of safety is the number obtained by dividing the bursting pressure of a boiler by the working pressure. Thus, if the bursting pressure is 800 pounds to the square inch and the working pressure is 200 pounds, the

factor of safety is  $\frac{800}{200} = 4$ ; that is, the working pressure is only one-quarter of the bursting pressure. The Federal regulations prescribe a minimum factor of safety of 4.

**110. Calculation of Working Pressure.**—The following rule for the calculation of the working pressure can be deduced from Art. 109:

**Rule.**—To find the maximum allowable working pressure, divide the bursting pressure by the factor of safety.

#### CALCULATION OF STRESSES ON FIREBOX

**111. Nature of Stresses.**—The firebox is subjected to two kinds of stresses, one due to the steam pressure and the other to the unequal expansion and contraction of the firebox sheets and the wrapper sheet. The steam pressure acts to bulge the firebox sheets inwards, the crown-sheet downwards, and the wrapper sheet outwards, but as this sheet is somewhat thicker than the firebox sheets the tendency for it to bulge is less.

With the steam pressure acting in one direction to force the wrapper sheet outwards, and in the opposite direction to force the firebox sheets inwards, the stress that tends to separate the sheets, aside from the slight tendency to bulge between the stays, comes not on the sheets but wholly on the stays and imposes a heavy tensile or stretching stress on them. Were it not for the stays, the firebox sheets and the wrapper sheet would have to be made very thick, but by using stays the sheets can be made comparatively thin. The circular part, or barrel, of the boiler is, on the contrary, self-supporting and stays are unnecessary, so that the pressure of the steam in this case induces a heavy tensile stress entirely on the sheets; hence the necessity for multiple-riveted butt joints in the longitudinal seams of the courses. However, as the firebox sheets and the wrapper sheet are almost entirely supported by the stays, single- or double-riveted lap joints or welded joints afford ample strength.

**112.** The only tensile stress induced in the side sheets of the firebox is that due to the downward pressure of the steam on

the mud-ring as well as on the narrow margin of the firebox at the corners not supported by stays. This is so small that it may be disregarded; hence, as far as the steam pressure is concerned, the tensile strength of the firebox sheets does not enter greatly into the problem of firebox stresses. However, the stresses induced by unequal expansion and contraction of the sheets often exceed those due to the pressure of the steam, so that firebox steel must possess a high tensile strength so as to be thin enough to transfer heat rapidly, and thick enough to prevent

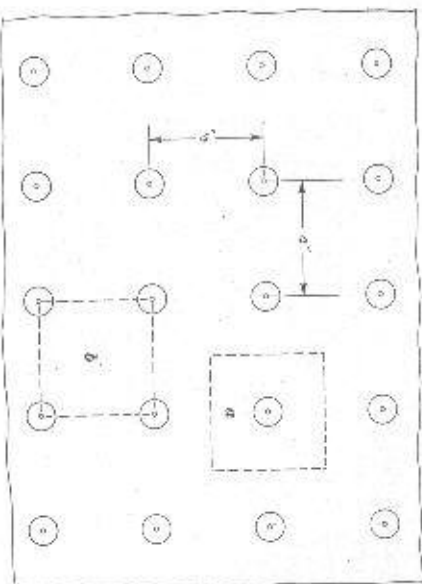

FIG. 38

bulging as well as to take in enough threads of the staybolts for support. The thickness of the firebox sheets seldom exceeds  $\frac{3}{8}$  inch and the thread found to be best adapted to boiler work is twelve to the inch, so that the greatest number of threads that can enter the sheet is four and one-half.

The shape of a locomotive firebox, as far as the water legs are concerned, is due to the necessity for a mud-ring in order that the rear end of the boiler may be secured to the frame. Such a construction also, of course, gives a maximum heating surface.

**113. Spacing of Stays.**—The stays are spaced close enough to prevent the sheet from bulging and their cross-sectional area is sufficient to prevent them from pulling apart. The staybolts are usually spaced 4 inches apart in each direction and it is

assumed that each staybolt supports the sheet halfway to the next staybolt, as shown at *a*, in Fig. 38. With such a spacing, the area supported by one staybolt is a square, 4 inches by 4 inches, or an area of 16 square inches; or the quarters of four staybolts may be considered as supporting the same area, as shown at *b*. The stress on a staybolt with a boiler pressure of 250 pounds to the square inch would then be  $16 \times 250$ , or a pressure of 4,000 pounds, although it is permissible to deduct the area of the staybolt at its smallest point from this area.

**114. Tensile Strength of Stays.**—The maximum allowable tensile strength that can be used in staybolt calculations is 7,500 pounds per square inch of cross-sectional area, although the actual tensile strength of staybolt material must fall between 47,000 and 52,000 pounds per square inch of cross-sectional area. Using only 7,500 pounds when the actual tensile strength is as stated insures an ample factor of safety or more than six. Hence the firebox has a higher factor of safety than the shell of the boiler, which may have as low a factor of safety as 4. The cross-sectional area of the smallest staybolt that could be used with a pressure of 250 pounds and a spacing of 4 inches would be  $\frac{4,000}{7,500}$  square inch, or one with an approximate diameter of nearly  $\frac{7}{8}$  inch. This diameter must be the smallest section of the staybolt, because the body of many staybolts is reduced at the middle to a smaller diameter than at the bottom of the thread. With a straight-body staybolt and a continuous thread the diameter is measured at the root of the thread. Drilling the telltale hole in the staybolt also reduces its strength, hence the area of the hole must be deducted when calculating the tensile strength of the bolt.

The holding power of the thread on the staybolt should be equal to its tensile strength, otherwise it would strip before the bolt would fail. As a means of aiding the thread as well as making the stay steam-tight, the ends are extended through the sheets and riveted over.

**115. Maximum Boiler Pressure.**—The maximum boiler pressure that can be carried for a certain specified spacing and

minimum staybolt diameter can be easily calculated by remembering that the area supported by one staybolt multiplied by the boiler pressure will equal the tensile stress on the staybolt. With a 4-inch spacing each way, thus giving an area support of 16 square inches, and staybolts with a least diameter of 1 $\frac{7}{8}$  inches, hence with a cross-sectional area of .886 square inch, less the area of the telltale hole, .028 inch, or a net area of .858 square inch, the maximum boiler pressure would be equal to  $\frac{7,500 \times .858}{16}$

= 402 pounds. It will be noted that the area supported is equal to the product of the spacing taken each way.

The foregoing shows that the pressure for which a firebox can be stayed depends on the spacing of the stays and their cross-sectional area. Owing to the difficulty in washing out if the spacing were made smaller and the diameter of the stays were increased, the spacing has to be at least about 4 inches and the stay diameter about 1 inch, this giving a distance between stays of 3 inches.

#### CALCULATING STRESSES DESIGNATED ON SPECIFICATION CARD

**116. Stresses on Staybolts and Crown Stays.**—The Specification Card Form No. 4, Rules and Instructions for Inspection and Testing of Locomotive Boilers and Their Appurtenances, requires the following calculations to be made and the results entered in the proper spaces on the card: The maximum stress on the staybolts at the root of the thread, in pounds per square inch, at the allowed working pressure; the stress on the staybolts at reduced section; the stress on the crown stays or crown-bar rivets at root of thread or smallest section, top; the stress on the crown stays or crown-bar rivets at root of thread or smallest section, bottom.

The above stresses can all be calculated from the following rule:

**Rule.**—To calculate the stress on a staybolt or a crown stay, in pounds per square inch, of cross-sectional area at either the root of the thread or at the reduced section, multiply the boiler pressure by the area supported by the staybolt and divide by the

*cross-sectional area at root of thread less the area of telltale hole, or by the cross-sectional area at the reduced section.*

117. It is to be understood that if any part of a crown stay is found to be smaller in area than the section at the root of the thread, then the lesser area is to be used. With a staybolt, the area of the telltale hole must be deducted from the least cross-sectional area.

EXAMPLE.—Find the stress on a staybolt in pounds per square inch of cross-sectional area with a spacing of 4 inches by 4 inches, a boiler pressure of 200 pounds to the square inch, and a diameter of 1 inch.

TABLE I  
AREA OF BOILER STAYS AT ROOT OF THREAD  
12 Threads Per Inch, V Thread

Size of stays Inches	Area of Stays at Root of Thread Deduct .028 sq. in. if telltale hole is used.
$\frac{1}{8}$	.419
$\frac{3}{16}$	.494
1	.575
1 $\frac{1}{8}$	.662
$\frac{1}{4}$	.755
$\frac{3}{4}$	.960

SOLUTION.—From Table I, the area of the staybolt at the root of the thread is .575 sq. in. With a telltale hole  $\frac{1}{8}$  in. in diameter, an area equal to .028 sq. in. must be subtracted, leaving an area of .547 sq. in. Then,  $4 \times 4 \times 200 = 5,580$  lb. per square inch of cross-sectional area. Ans.

118. **Stresses on Round and Rectangular Braces.**—The method of calculating the stress on round and rectangular braces that are placed diagonally can be understood from a study of Fig. 39. The area supported by the stay is found in the same manner as for a staybolt, namely, each brace is assumed to support the plate halfway to the next one on all of the four sides; or, if an upper brace, the measurement is made to a point 2 inches from the flange of the tube-sheet. An area of 36 square inches will be taken; this multiplied by a boiler pressure of 200 pounds

will give a stress of 7,200 pounds on an assumed direct brace. (Owing to the diagonal position of the actual brace, the stress on it is more than if the brace were direct, the stress varying as the length. Thus, with a stress of 7,200 pounds on a direct brace of a length of 60 inches, the stress on a diagonal brace 66 inches long will be  $\frac{66}{60} \times 7,200$ , or 7,920, pounds. Dividing this by the minimum or smallest cross-sectional area of the diagonal brace, here assumed to be 1 $\frac{1}{4}$  square inches, gives a stress of  $\frac{7,920}{1\frac{1}{4}}$ , or 6,336, pounds per square inch of cross-sectional area. As this is much less than the 9,000 pounds permitted by the rules, the brace is amply strong.

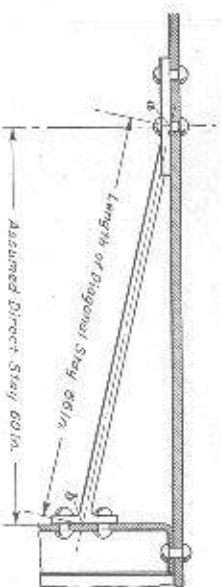

FIG. 39

The solution of this problem is dependent on the length of the assumed direct brace. This length can be found closely enough by suspending a plumb line as nearly as possible at the junction *a* of the center line of the brace with the shell, and then measuring the distance to the tube-sheet. The length of the diagonal brace is measured from *a* to the foot at *b*.

The calculation of the stress on a diagonal brace at the back head will not differ to any great extent from that at the tube-sheet. A slight error will exist owing to the slope of the back head, but this error is on the safe side, and does not have to be considered.

119. **Gusset Stays.**—Owing to the abrupt angle of the gusset stays, Fig. 40, their cross-sectional areas, according to the A. S. M. E. rules, must be 10 per cent. greater than the area of a diagonal stay under the same stress, but the I. C. C. rules

do not require this extra allowance. The method of calculating the stress is the same as already given for diagonal braces.

**120. Shearing Stress on Rivets in Diagonal Braces.** Referring to Fig. 39, a pull of 7,200 pounds on the assumed direct brace is resisted by two rivets in single shear in the shell. The shearing stress on the rivets is not equal to the pull on the diagonal brace, because 720 pounds of the pull is exerted as a tensile stress on the rivets, and is so small as compared with

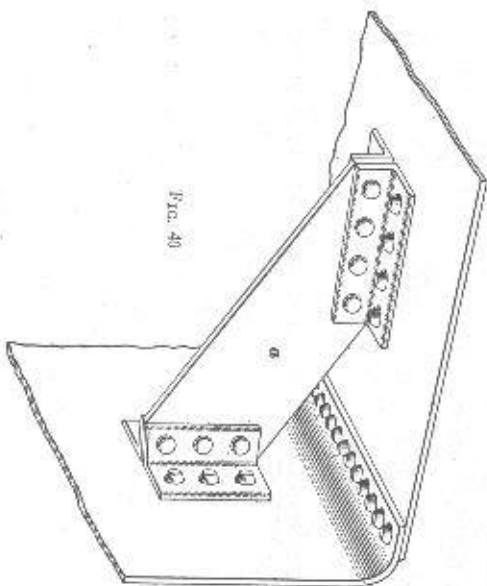

common tensile stresses that it does not have to be considered. To determine the shearing stress on these rivets, in pounds per square inch of cross-sectional area, divide the combined cross-sectional area of the two rivets into whatever stress is found to be exerted on the assumed direct brace, here assumed to be 7,200 pounds. The stress on an iron rivet in single shear should not exceed 9,500 pounds per square inch; for a steel rivet a stress of 11,000 pounds per square inch is permitted. These values are obtained by dividing the figures given in Rule 5, Rules and Instructions for Inspection and Testing of Locomotive Boilers and Their Appendances, found in the back of this lesson, by the factor of safety, or 4. According to Rule 6, a higher value may be taken when a greater strength of rivet material can be shown.

The tensile stress is also developed on the rivets that secure the brace to the tube-sheet. The combined area of the rivets, in square inches, divided into 7,200 will give the tensile stress per square inch.

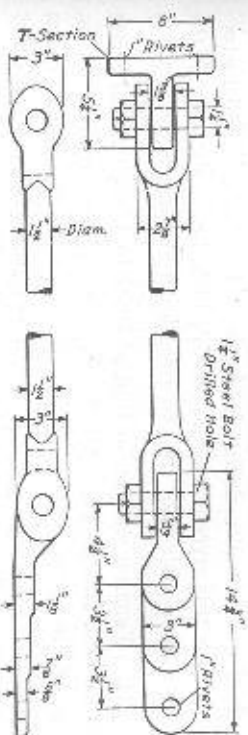

With diagonal braces of the type shown in Fig. 41, the pin is in double shear. To determine the shearing stress, in pounds per square inch of cross-sectional area, divide the stress on the

TABLE II  
AREA OF RIVET HOLES

Size of Driven Rivets Inches	Area of Rivet Hole Square Inches
$\frac{1}{16}$	.371
$\frac{3}{16}$	.442
$\frac{1}{8}$	.518
$\frac{5}{16}$	.601
$\frac{3}{8}$	.690
$\frac{7}{16}$	.785
1	.887
1 1/8	.994
1 1/4	1.050
1 3/8	1.108
1 1/2	1.227
1 5/8	1.353

diagonal brace, which is assumed to be 7,920 pounds, by the cross-sectional area of the steel pin. The reason why the stress on the diagonal stay is taken is that the pin is actually a part of the brace. According to Rule 5 of the foregoing regulations,

the result of the calculation must be under 22,000 pounds per square inch.

The area of rivet holes for various sizes of rivets is given in Table II. The area of the drilled hole is always to be taken, and not the cross-sectional area of the rivet before it is driven. An inch rivet is usually driven into a hole  $1\frac{1}{16}$  inches in diameter; in driving this rivet it is expanded  $\frac{1}{16}$  inch, hence the area of the hole is taken instead of the cross-sectional area of the rivet.

**121. Tension on Net Section of Plate in Longitudinal Seam of Lowest Efficiency.**—The analysis of a longitudinal seam, Fig. 36, to determine the point of lowest efficiency was given in Arts. 95 to 100, the lowest resistance to rupture being found in the plate between the rivet holes in the third row.

**122. Calculating Efficiency of Weakest Longitudinal Seam.**  
If the weakest part of the seam is assumed to be the net section of plate at the outer row of rivets, then its efficiency can be calculated from Rule II, Art. 84. However, if this assumption is not to be made, the weakest part of the seam can be calculated from the rule in Art. 90.

SUMMARY OF RULES

123. The rules given throughout this lesson are here arranged in a convenient form for reference.

Tensile strength of plate = cross-sectional area  $\times$  unit of tensile strength.

Efficiency of plate (at outer row of rivets)

$$= \frac{\text{pitch} - \text{diameter of rivet hole}}{\text{pitch}} \times 100.$$

Shearing stress of rivets = cross-sectional area  $\times$  unit of shearing stress.

Efficiency of joint =  $\frac{\text{weakest part of joint}}{\text{ultimate strength of plate}} \times 100.$

Efficiency of joint (if equal to efficiency of plate)

$$= \frac{\text{pitch} - \text{diameter of rivet hole}}{\text{pitch}} \times 100.$$

Strain on longitudinal seam = radius of boiler  $\times$  length  $\times$  pressure.

Bursting pressure

$$= \frac{\text{minimum thickness of plate} \times \text{tensile strength} \times \text{efficiency of joint}}{\text{radius of shell}}$$

Safe working pressure (boiler shell)

$$= \frac{\text{minimum thickness of plate} \times \text{tensile strength} \times \text{efficiency of joint}}{\text{radius of shell} \times \text{factor of safety}}$$

Safe working pressure (firebox)

$$= \frac{7,500 \times \text{net area of staybolt}}{\text{vertical pitch} \times \text{horizontal pitch}}$$

Stress on staybolts (root of thread)

$$= \frac{\text{cross-sectional area, root of thread} - \text{area of telltale hole}}{\text{boiler pressure} \times \text{area supported}}$$

Stress on crown stays (root of thread)

$$= \frac{\text{boiler pressure} \times \text{area supported}}{\text{cross-sectional area, root of thread}}$$

Stress on diagonal braces

$$= \frac{\text{boiler pressure} \times \text{area supported} \times \text{length of stay}}{\text{length of assumed direct stay}}$$

**RULES AND INSTRUCTIONS FOR INSPECTION AND TESTING OF LOCOMOTIVE BOILERS AND THEIR APPURTENANCES.**

Approved by orders of the Interstate Commerce Commission, dated June 2, 1911, September 12, 1912, June 9, 1914, April 7, 1918, and July 28, 1925.

**RESPONSIBILITY FOR THE GENERAL CONSTRUCTION AND SAFE WORKING PRESSURE.**

1. The railroad company will be held responsible for the general design and construction of the locomotive boilers under its control. The safe working pressure for each locomotive boiler shall be fixed by the chief mechanical officer of the company or by a competent mechanical

engineer under his supervision, after full consideration has been given to the general design, workmanship, age, and condition of the boiler, and shall be determined from the minimum thickness of the shell plates, the lowest tensile strength of the plates, the efficiency of the longitudinal joint, the inside diameter of the course, and the lowest factor of safety allowed.

#### FACTOR OF SAFETY.

- The lowest factor of safety for locomotive boilers which were in service or under construction prior to January 1, 1912, shall be 3.25. Effective October 1, 1919, the lowest factor shall be 3.5. Effective January 1, 1921, the lowest factor shall be 3.75. Effective January 1, 1923, the lowest factor shall be 4.

3. (a) *Maximum allowable stress on stays and braces*.—For locomotives constructed after January 1, 1915, the maximum allowable stress per square inch of net cross-sectional area on firebox and combustion chamber stays shall be 7,500 pounds. The maximum allowable stress per square inch of net cross-sectional area on round, rectangular, or gusset braces shall be 9,000 pounds.

(b) For locomotives constructed prior to January 1, 1915, the maximum allowable stress on stays and braces shall meet the requirements of rule No. 2, except that when a new firebox and wrapper sheet are applied to such locomotives they shall be made to meet the requirements of rule No. 3.

#### TENSILE STRENGTH OF MATERIAL.

- When the tensile strength of steel or wrought-iron shell plates is not known, it shall be taken at 50,000 pounds for steel and 45,000 pounds for wrought iron.

#### SHEARING STRENGTH OF RIVETS.

- The maximum shearing strength of rivets per square inch of cross-sectional area shall be taken as follows:

Iron rivets in single shear.....	38,000
Iron rivets in double shear.....	76,000
Steel rivets in single shear.....	44,000
Steel rivets in double shear.....	88,000

- A higher shearing strength may be used for rivets when it can be shown by test that the rivet material used is of such quality as to justify a higher allowable shearing strength.

#### RULES FOR INSPECTOR.

- The mechanical officer in charge at each point where boiler work is done will be held responsible for the inspection and repair of all locomotive boilers and their appliances under his jurisdiction. He must know that all defects disclosed by any inspection are properly repaired before the locomotive is returned to service.

- The term "inspector" as used in these rules and instructions, unless otherwise specified, will be held to mean the railroad company's inspector.

#### INSPECTION OF INTERIOR OF BOILER.

- Time of inspection*.—The interior of every boiler shall be thoroughly inspected before the boiler is put into service and whenever a sufficient number of flues are removed to allow examination.

10. *Flues to be removed*.—All flues of locomotive boilers in service, except as otherwise provided, shall be removed at least once every four years for the purpose of making a thorough examination of the entire interior of the boiler and its bracing. After the flues are taken out the inside of the boiler must have the scale removed and be thoroughly cleaned and inspected. The removal of flues will be due after 48 calendar months' service, provided such service is performed within five consecutive years. Portions of calendar months out of service will not be counted. Time out of service must be properly accounted for by out of service reports and notations of months cleaned out of service made on the back of each subsequent inspection report and cab card. The period for removal of flues, upon formal application to the chief inspector, may be extended, if investigation shows that conditions warrant it.

11. *Method of inspection*.—The entire interior of the boiler must then be examined for cracks, pitting, grooving, or indications of overheating and for damage where mud has collected or heavy scale formed. The edges of plates, all laps, seams, and points where cracks and defects are likely to develop or which an exterior examination may have indicated, must be given an especially minute examination. It may be seen that braces and stays are taut, that pins are properly secured in place, and that each is in condition to support its proportion of the load.

12. *Repairs*.—Any boiler developing cracks in the barrel shall be taken out of service at once, thoroughly repaired, and reported to be in satisfactory condition before it is returned to service.

13. *Lap-joint seams*.—Every boiler having lap-joint longitudinal seams without reinforcing plates shall be examined with special care to detect grooving or cracks at the edges of the seams.

14. *Portable plugs*.—If boilers are equipped with invisible plugs they shall be removed and cleaned of scale at least once every month. Their removal must be noted on the report of inspection.

#### INSPECTION OF EXTERIOR OF BOILER.

15. *Time of inspection*.—The exterior of every boiler shall be thoroughly inspected before the boiler is put into service and whenever the jacket and the lagging are removed.

16. *Lagging to be removed*.—The jacket and lagging shall be removed at least once every five years and a thorough inspection made of the entire

exterior of the boiler while under hydrostatic pressure. The jacket and lagging shall also be removed whenever on account of indications of leaks the United States inspector or the railroad company's inspector considers it desirable or necessary. The modification granted in rule 16 in the commissioner's order of September 20, 1917, on account of the war in which the date for removal of jacket and lagging was advanced for a period equivalent to the duration of the war, such advanced period shall be considered two years.

## TESTING BOLTERS.

17. *Time of testing.*—Every boiler, before being put into service and at least once every 12 months thereafter, shall be subjected to hydrostatic pressure 25 per cent above the working steam pressure.

18. *Removal of dome cap.*—The dome cap and throttle standpipe must be removed at the time of making the hydrostatic test and the interior surface and connections of the boiler examined as thoroughly as conditions will permit. In case the boiler can be entered and thoroughly inspected without removing the throttle standpipe the inspector may make the inspection by removing the dome cap only, but the variation from the rule must be noted in the report of inspection.

19. *Witness of test.*—When the test is being made by the railroad company's inspector, an authorized representative of the company, thoroughly familiar with boiler construction, must personally witness the test and thoroughly examine the boiler while under hydrostatic pressure.

20. *Repairs and steam test.*—When all necessary repairs have been completed, the boiler shall be fired up and the steam pressure raised to not less than the allowed working pressure, and the boiler and appurtenances carefully examined. All cocks, valves, seams, bolts, and rivets must be tight under this pressure and all defects disclosed must be repaired.

## STAYBOLT TESTING.

21. *Time of testing rigid bolts.*—All staybolts shall be tested at least once each month. Staybolts shall also be tested immediately after every hydrostatic test.

22. *Method of testing rigid bolts.*—The inspector must tap each bolt and determine the broken bolts from the sound or the vibration of the sheet. If staybolt tests are made when the boiler is filled with water, there must be not less than 50 pounds pressure on the boiler. Should the boiler not be under pressure, the test may be made after draining all water from the boiler, in which case the vibration of the sheet will indicate any unsoundness. The latter test is preferable.

23. *Method of testing flexible staybolts with caps.*—Except as provided in paragraph (5), all staybolts having caps over the outer ends shall have the caps removed at least once every two (2) years and the

bolts and sleeves examined for breakage. Each time the hydrostatic test is applied the hammer test required by rules 21 and 22 shall be made while the boiler is under hydrostatic pressure not less than the allowed working pressure.

(b) When all flexible staybolts with which any boiler is equipped are provided with a telltale hole not less than three-sixteenths ( $\frac{3}{16}$ ) inch nor more than seven thirty-seconds ( $\frac{7}{32}$ ) inch in diameter, extending the entire length of the bolt and into the head not less than one-third ( $\frac{1}{3}$ ) of its diameter, and these bolts are protected from becoming closed by rust and corrosion by copper plating or other approved method, and are opened and tested, each time the hydrostatic test is applied, with an electrical or other instrument approved by the Bureau of Locomotive Inspection, that will positively indicate when the telltale holes are open their entire length, the caps will not be required to be removed. When this test is completed the hydrostatic test must be applied and all staybolts removed which show leakage through the telltale hole.

The inner ends of the telltale holes must be kept closed with a fire-proof porous material that will exclude foreign matter and permit leakage of steam or water, if the bolt is broken or fractured, into the telltale hole. When this test is completed the ends of the telltale holes shall be closed with material of different color than that removed and a record kept of colors used.

(c) The removal of flexible staybolt caps and other tests shall be reported on the report of inspection Form No. 3, and a proper record kept in the office of the railroad company of the inspections and tests made.

(d) Firebox sheets must be carefully examined at least once every month for small burn, bulging, and indication of broken staybolts.

(e) Staybolt caps shall be removed or any of the above tests made whenever the United States inspector or the railroad company's inspector considers it desirable in order to thoroughly determine the condition of staybolts or staybolt sleeves.

24. *Method of testing flexible staybolts without caps.*—Flexible staybolts which do not have caps shall be tested once each month, the same as rigid bolts.

Each time a hydrostatic test is applied such staybolt test shall be made while the boiler is under hydrostatic pressure not less than the allowed working pressure and proper notation of such test made on Form No. 3.

25. *Broken staybolts.*—No boiler shall be allowed to remain in service when there are two adjacent staybolts broken or plugged in any part of the firebox or combustion chamber, nor when three or more are broken or plugged in a circle 4 feet in diameter, nor when five or more are broken or plugged in the entire boiler.

26. *Telltale holes*.—All staybolts shorter than 8 inches applied after July 1, 1914, except flexible bolts, shall have telltale holes three-sixteenths inch in diameter and not less than 14 inches deep in the outer end. These holes must be kept open at all times.

27. All staybolts shorter than 8 inches, except flexible bolts and rigid bolts which are behind frames and braces, shall be drilled when the locomotive is in the shop for heavy repairs, and this work must be completed prior to July 1, 1914.

#### STEAM GAUGES.

28. *Locations of gauges*.—Every boiler shall have at least one steam gauge which will correctly indicate the working pressure. Care must be taken to locate the gauge so that it will be kept reasonably cool and can be conveniently read by the enginemen.

29. *Syphon*.—Every gauge shall have a syphon of ample capacity to prevent steam entering the gauge. The pipe connection shall enter the boiler direct and shall be maintained steam tight between boiler and gauge. The syphon pipe and its connections to the boiler must be cleaned each time the gauge is tested.

30. *Time of testing*.—Steam gauges shall be tested at least once every three months and also when any irregularity is reported.

31. *Method of testing*.—Steam gauges shall be compared with an accurate test gauge or dead-weight tester and gauges found inaccurate shall be corrected before being put into service.

32. *Badge plates*.—A metal badge plate showing the allowed steam pressure shall be attached to the boiler head in the cab. If boiler head is lagged, the lagging and jacket shall be cut away so that the plate can be seen.

33. *Boiler number*.—The builder's number of the boiler, if known, shall be stamped on the dome. If the builder's number of the boiler can not be obtained, an assigned number which shall be used in making out specification cards shall be stamped on dome.

#### SAFETY VALVES.

34. *Number and capacity*.—Every boiler shall be equipped with at least two safety valves, the capacity of which shall be sufficient to prevent, under any conditions of service, an accumulation of pressure more than 5 per cent. above the allowed steam pressure.

35. *Setting of safety valves*.—Safety valves shall be set to pop at pressures not exceeding 6 pounds above the working steam pressure. When setting safety valves two steam gauges shall be used, one of which must be so located that it will be in full view of the person engaged in setting such valves; and if the pressure indicated by the gauges varies

more than 3 pounds they shall be removed from the boiler, tested, and corrected before the safety valves are set. Gauges shall in all cases be tested immediately before the safety valves are set or any change made in the setting. When setting safety valves the water level in the boiler shall not be above the highest gauge cock.

36. *Time of testing*.—Safety valves shall be tested under steam at least once every three months, and also when any irregularity is reported.

#### WATER GLASS AND GAUGE COCKS

37. *Number and locations*.—Every boiler shall be equipped with at least one water glass and three gauge cocks. The lowest gauge cock and the lowest reading of the water glass shall be not less than 3 inches above the highest part of the crown-sheet. Locomotives which are not now equipped with water glasses shall have them applied on or before July 1, 1912.

38. *Water glass valves*.—All water glasses shall be supplied with two valves or shut-off cocks, one at the upper and one at the lower connection to the boiler, and also a drain cock, so constructed and located that they can be easily opened and closed by hand.

39. *Time of cleaning*.—The spindles of all gauge cocks and water glass cocks shall be removed and cocks thoroughly cleaned of scale and sediment at least once each month.

40. All water glasses must be blown out and gauge cocks tested before each trip and gauge cocks must be maintained in such condition that they can be easily opened and closed by hand without the aid of a wrench or other tool.

41. *Water and indicator glass shields*.—All tubular water glasses and indicator glasses must be equipped with a safe and suitable shield which will prevent the glass from flying in case of breakage, and such shield shall be properly maintained.

42. *Water glass lamps*.—All water glasses must be supplied with a suitable lamp properly located to enable the engineer to easily see the water in the glass.

#### INJECTORS.

43. Injectors must be kept in good condition, free from scale, and must be tested before each trip. Boiler clocks, delivery pipes, feed water pipes, tank hose and tank valves must be kept in good condition, free from leaks and from foreign substances that would obstruct the flow of water.

#### PISTON PIPES.

44. Piston pipes must be provided with a hole through the center not less than three-fourths inch in diameter. When one or more tubes are

plugged at both ends the plugs must be tied together by means of a rod not less than five-eighths inch in diameter. Fine plugs must be removed and flues repaired at the first point where such repairs can properly be made.

#### WASHING BOILERS.

43. *Time of washing.*—All boilers shall be thoroughly washed as often as the water conditions require, but not less frequently than once each month. All boilers shall be considered as having been in continuous service between washouts unless the dates of the days that the boiler was out of service are properly certified on washout reports and the report of inspection.

46. *Plugs to be removed.*—When boilers are washed, all washout arch, and water bar plugs must be removed.

47. *Water tubes.*—Special attention must be given the arch and water bar tubes to see that they are free from scale and sediment.

48. *Office record.*—An accurate record of all locomotive boiler washouts shall be kept in the office of the railroad company. The following information must be entered on the day that the boiler is washed:

- (a) Number of locomotive.
- (b) Date of washout.
- (c) Signature of boiler washer or inspector.
- (d) Statement that spindles of gauge cocks and water-glass cocks were removed and cocks cleaned.
- (e) Signature of the boiler inspector or the employe who removed the spindles and cleaned the cocks.

#### STEAM LEAKS.

49. *Leak's and/or tagging.*—If a serious leak develops under the tagging, an examination must be made and the leak located. If the leak is found to be due to a crack in the shell or to any other defect which may reduce safety, the boiler must be taken out of service at once, thoroughly repaired, and reported to be in satisfactory condition before it is returned to service.

50. *Leak's in front of enginemen.*—All steam valves, cocks, and joints, studs, bolts, and seams shall be kept in such repair that they will not emit steam in front of the enginemen, so as to obscure their vision.

#### FILING REPORTS.

51. *Report of inspection.*—Not less than once each month and within 10 days after each inspection a report of inspection, Form No. 1, size 6 by 9 inches, shall be filed with the district inspector of locomotive boilers for each locomotive used by a railroad company, and a copy shall be filed in the office of the chief mechanical officer having charge of the locomotive.

52. A copy of the monthly inspection report, Form No. 1, or annual inspection report, Form No. 3, properly filed out, shall be placed under glass in a conspicuous place in the cab of the locomotive before the boiler inspected is put into service.

53. Not less than once each year and within 10 days after hydrostatic and other required tests have been completed a report of such tests showing general condition of the boiler and repairs made shall be submitted on Form No. 3, size 6 by 9 inches, and filed with the district inspector of locomotive boilers, and a copy shall be filed in the office of the chief mechanical officer having charge of the locomotive. The monthly report will not be required for the month in which this report is filed.

54. (a) *Specification card.*—A specification card, size 8 by 10½ inches, Form No. 4, containing the results of the calculations made in determining the working pressure and other necessary data shall be filed in the office of the chief inspector of locomotive boilers for each locomotive boiler. A copy shall be filed in the office of the chief mechanical officer having charge of the locomotive. Every specification card shall be verified by the chief of the engineer making the calculations, and shall be approved by the chief mechanical officer. These specification cards shall be filed as promptly as thorough examination and accurate calculation will permit. Where accurate drawings of boilers are available, the data for specification card, Form No. 4, may be taken from the drawings, and such specification cards must be completed and forwarded prior to July 1, 1912. Where accurate drawings are not available, the required data must be obtained at the first opportunity when general repairs are made, or when flues are removed. Specification cards must be forwarded within one month after examination has been made, and all examinations must be completed and specification cards filed prior to July 1, 1913, flues being removed if necessary to enable the examination to be made before this date.

(b) When any repairs or changes are made which affect the data shown on the specification card a corrected card or an alteration report on an approved form, size 8 by 10½ inches, properly certified to, giving details of such changes, shall be filed within 30 days from the date of their completion. This report should cover:

- A. Application of new barrel sheets or domes.
- B. Application of patches to barrels or domes of boilers or to portion of wrapper sheet of crown bar boilers which is not supported by staybolts.
- C. Longitudinal seam reinforcements.
- D. Changes in size or number of braces, giving maximum stress.
- E. Initial application of superheaters, arch or water-bar tubes, giving number and dimensions of tubes.
- F. Changes in number or capacity of safety valves.

Report of patches should be accompanied by a drawing or blueprint of the patch, showing its location in regard to the center line of boiler, giving all necessary dimensions, and showing the nature and location of the defect. Patches previously applied should be reported the first time the boiler is stripped to permit an examination.

ACCIDENT REPORTS.

53. In the case of an accident resulting from failure, from any cause, of a locomotive boiler or any of its appurtenances, resulting in serious injury or death to one or more persons, the carrier owning or operating such locomotive shall immediately transmit by wire to the chief inspector of locomotive boilers, at his office in Washington, D. C., a report of such accident, stating the nature of the accident, the place at which it occurred, as well as where the locomotive may be inspected, which wire shall be immediately confirmed by mail, giving a full detailed report of such accident, stating, as far as may be known, the causes and giving a complete list of the killed or injured.

MONTHLY LOCOMOTIVE INSPECTION AND REPAIR REPORT.

Form No. 1.

.....19  
 .....Company.  
 Locomotive { Number.....  
 Initial.....

In accordance with the act of Congress approved February 17, 1911, as amended March 4, 1915, and the rules and instructions issued in pursuance thereof and approved by the Interstate Commerce Commission, all parts of locomotive No. ...., including the boiler and appurtenances, were inspected on ..... 19 .. at .., and all defects disclosed by said inspection have been repaired, except as noted on the back of this report.

- |   |  |
|---|--|
| 1. Steam gauges tested and left in good condition on..... 19 ..                   | 10. Was boiler washed and gauge cocks and water glass cock spindles removed and cocks cleaned? ..... |
| 2. Safety valves set to pop at.....pounds, .....pounds, .....pounds on..... 19 .. | 11. Were steam leaks repaired? .....   |
| 3. Were both injectors tested and left in good condition? .....                   | 12. Condition of staybolts and crown stays, .....  |
| 4. Were steam leaks repaired? .....   | 13. Number of staybolts and crown stays renewed, .....   |
| 5. Condition of brake and signal equipment, .....                                 | 14. Condition of flues and firebox sheets, .....   |
| 6. Condition of draft gear and draw gear, .....                                   | 15. Condition of arch and water bar tubes, if used, .....  |
| 7. Condition of driving gear, .....   | 16. Were fusible plugs removed and cleaned? .....  |
| 8. Condition of running gear, .....   | 17. Date of previous hydrostatic test, ..... 19 ..   |
| 9. Condition of tender, .....   | 18. Date of removal of caps from flexible staybolts, ..... 19 ..                                     |
| I certify that the above report is correct.<br>.....<br>Inspector.                | I certify that the above report is correct.<br>.....<br>Inspector.                                   |

STATE OF..... }  
 COUNTY OF..... } ss:

Subscribed and sworn to before me this.....day of.....19 .., by....., inspectors  
 of the.....Company. ....  
 Notary Public.

The above work has been performed and the report is approved.  
 .....

.....  
 Officer in Charge.

ANNUAL LOCOMOTIVE INSPECTION AND REPAIR REPORT.

Form No. 3.

.....19

.....Company.

Locomotive { Number.....  
Initial.....

In accordance with the act of Congress approved February 17, 1911, as amended March 4, 1913, and the rules and instructions issued in pursuance thereof and approved by the Interstate Commerce Commission, all parts of locomotive No. ...., including the boiler and appliances, were inspected on ..... 19 .. at .., and all defects disclosed by said inspection have been repaired, except as noted on the back of this report.

- |  |                     |   |                        |
|--|---------------------|---|------------------------|
| 1. Date of previous hydrostatic test, .....                        | 19 ..               | 12. Was boiler washed? Water glass cocks and gauge cocks cleaned? ..... | .....                  |
| 2. Date of previous removal of caps from flexible staybolts, ..... | 19 ..               | 13. Condition of crown stays and staybolts, .....                       | .....                  |
| 3. Date of previous removal of flues, .....                        | 19 ..               | 14. Condition of sling stays and crown bars, .....                      | .....                  |
| 4. Date of previous removal of all lagging, .....                  | 19 ..               | 15. Condition of firebox sheets and flues, .....                        | .....                  |
| 5. Hydrostatic test pressure of .....                              | pounds was applied. | 16. Condition of arch tubes, .....                                      | Water bar tubes, ..... |
| 6. Were caps removed from all flexible staybolts? .....            | Number.....         | 17. Condition of crown braces, .....                                    | .....                  |
| 7. Were all flues removed? .....                                   | .....               | 18. Condition of back head braces, .....                                | .....                  |
| 8. Condition of interior of barrel, .....                          | .....               | 19. Condition of front flue sheet braces, .....                         | .....                  |
| 9. Was all lagging removed? .....                                  | .....               | 20. Were fusible plugs removed and cleaned? .....                       | .....                  |
| 10. Condition of exterior of barrel, .....                         | .....               | 21. Were steam leaks repaired? .....                                    | .....                  |
| 11. Was boiler entered and inspected? .....                        | .....               | .....   | Inspector.             |

I certify that the above report is correct.

- |  |                                    |  |       |
|--|------------------------------------|--|-------|
| 22. Were steam gauges tested and left in good condition? .....   | .....                              | 27. Condition of brake and signal equipment, .....             | ..... |
| 23. Safety valves set to pop at .....                            | pounds, .....                      | 28. Were drawbar and drawbar pins removed and inspected? ..... | ..... |
| .....  | pounds,                            | 29. Condition of draft gear and draw gear, .....               | ..... |
| 24. Were both injectors tested and left in good condition? ..... | .....                              | 30. Condition of driving gear, .....                           | ..... |
| 25. Were steam leaks repaired? .....                             | .....                              | 31. Condition of running gear, .....                           | ..... |
| 26. Hydrostatic test of .....                                    | pounds applied to main reservoirs. | 32. Condition of tender, .....                                 | ..... |

I certify that the above report is correct.

STATE OF.....  
COUNTY OF.....

Subscribed and sworn to before me this..... day of..... 19 .. by..... inspectors of the..... Company.

The above work has been performed and the report is approved.

....., Notary Public.  
....., Officer in Charge.

Form No. 4.

Specification Card for Locomotive No. ....

Owned by..... Railroad Company.  
Operated by..... Railroad Company.

Boiler: Builder's No. of Boiler.....  
When built.....  
Where built.....  
Type of boiler.....  
Material of boiler shell sheets.....  
Material of rivets.....  
Dome, where located.....  
Gate area in sq. ft.....  
Height of lower radius of gauge glass above crown sheet.....  
Height of lowest gauge cock above crown sheet.....  
Water bar tubes, O. diam., thickness.....  
Arch tubes, O. diam., thickness.....  
Fire tubes, number..... length.....  
Safety valves: No. Size. Make. Style.....  
Fusible plug bolts, O. diam., spaced.....  
Combustion chamber stay bolts, O. diam.....  
Crown stays, O. diam., top..... bottom.....  
Crown bar rivets, O. diam., top..... bottom.....  
Crown bar rivets, spaced.....  
Washer space at firebox top, sides.....  
back..... front.....  
Width of washer space at sides of firebox measured at center line of boiler front..... back.....

Make working sketch here or attach drawing of longitudinal and circumferential seams used in shell of boiler, indicating on which courses used, and give calculated efficiency of weakest longitudinal seam.

The maximum stresses at the allowed working pressure were found by calculation to be as follows:

Stay bolts at root of threads.....	lbs. per sq. in.	of thread on smallest section, bottom
Stay bolts at reduced section.....	lbs. per sq. in.	Round and rectangular braces.....
Crown stays or crown bar rivets at root of thread or smallest section, top.....	lbs. per sq. in.	Gusset braces.....
Crown stays or crown bar rivets at root of thread or smallest section, bottom.....	lbs. per sq. in.	Shearing stress on rivets.....
		Tension on net section of plate in longitudinal seam of torus thickness, pounds per sq. in.....

Dimensions and data taken from locomotive were furnished by.....  
Data upon which above calculations were made were obtained from drawing No. .... furnished by..... Company.  
..... Mechanical Engineer.

Shell sheets: Front tube..... thickness.....  
1st course..... I. diam.....  
2d.....  
3d.....  
4th.....  
5th.....  
6th.....  
7th.....  
8th.....  
9th.....  
10th.....  
11th.....  
12th.....  
13th.....  
14th.....  
15th.....  
16th.....  
17th.....  
18th.....  
19th.....  
20th.....  
21st.....  
22nd.....  
23rd.....  
24th.....  
25th.....  
26th.....  
27th.....  
28th.....  
29th.....  
30th.....  
31st.....  
32nd.....  
33rd.....  
34th.....  
35th.....  
36th.....  
37th.....  
38th.....  
39th.....  
40th.....  
41st.....  
42nd.....  
43rd.....  
44th.....  
45th.....  
46th.....  
47th.....  
48th.....  
49th.....  
50th.....  
51st.....  
52nd.....  
53rd.....  
54th.....  
55th.....  
56th.....  
57th.....  
58th.....  
59th.....  
60th.....  
61st.....  
62nd.....  
63rd.....  
64th.....  
65th.....  
66th.....  
67th.....  
68th.....  
69th.....  
70th.....  
71st.....  
72nd.....  
73rd.....  
74th.....  
75th.....  
76th.....  
77th.....  
78th.....  
79th.....  
80th.....  
81st.....  
82nd.....  
83rd.....  
84th.....  
85th.....  
86th.....  
87th.....  
88th.....  
89th.....  
90th.....  
91st.....  
92nd.....  
93rd.....  
94th.....  
95th.....  
96th.....  
97th.....  
98th.....  
99th.....  
100th.....

External firebox: Thickness of sheets - throat.....  
Roof..... sides.....  
Dome inside diam.....  
Thickness of sheet base.....  
Were you furnished with authentic records of the tests of materials used in boiler?  
Records on file in the office of the..... Company show that the lowest tensile strength of the sheets in the shell of this boiler is: 1st course..... pounds per sq. in. 2d..... 3d..... 4th..... 5th..... 6th..... 7th..... 8th..... 9th..... 10th..... 11th..... 12th..... 13th..... 14th..... 15th..... 16th..... 17th..... 18th..... 19th..... 20th..... 21st..... 22nd..... 23rd..... 24th..... 25th..... 26th..... 27th..... 28th..... 29th..... 30th..... 31st..... 32nd..... 33rd..... 34th..... 35th..... 36th..... 37th..... 38th..... 39th..... 40th..... 41st..... 42nd..... 43rd..... 44th..... 45th..... 46th..... 47th..... 48th..... 49th..... 50th..... 51st..... 52nd..... 53rd..... 54th..... 55th..... 56th..... 57th..... 58th..... 59th..... 60th..... 61st..... 62nd..... 63rd..... 64th..... 65th..... 66th..... 67th..... 68th..... 69th..... 70th..... 71st..... 72nd..... 73rd..... 74th..... 75th..... 76th..... 77th..... 78th..... 79th..... 80th..... 81st..... 82nd..... 83rd..... 84th..... 85th..... 86th..... 87th..... 88th..... 89th..... 90th..... 91st..... 92nd..... 93rd..... 94th..... 95th..... 96th..... 97th..... 98th..... 99th..... 100th.....

Is boiler shell circular at all points?.....  
If shell is flattened state location and amount.....  
Are all parts thoroughly stayed?.....  
Are dome and other openings sufficiently reinforced?.....  
Is boiler equipped with fusible plugs?.....

State of ..... }  
County of ..... }

being duly sworn says that he is the officer who  
signed the foregoing specification, that he has searched himself of the correctness of  
the drawings and data used, has verified all of the calculations, and has examined  
the record on present condition of boiler described ..... and sworn  
to by inspector ..... and believes that the design, construction,  
and condition of boiler No. .... renders it safe for a working pressure of .....  
pounds per square inch.

Subscribed and sworn to before me  
this ..... day of ..... 19 ..... (name of witness)

Approved: ..... Notary Public

.....